

FUSION



SEMI-HERMETIC
COMPRESSORS
50 Hz

Decodifica del modello**Model designation****Repérage des modèles****Modellschlüssel**

Esempio: Z 30 126 Y

Example: Z 30 126 Y

Exemple: Z 30 126 Y

zum Beispiel: Z 30 126 Y

Z 30 126 Y

Serie compressore
Compressor series
Séries de compresseur
Verdichterreihe

Potenza elettrica nominale	HP
Nominal electric power	HP
Puissance électrique nominale	HP
Motornennleistung	PS

Capacità volumetrica m ³ /h	(1450 giri/min)
Displacement m ³ /h	(1450 rpm)
Volume balayé m ³ /h	(1450 t/min)
Volumenstrom m ³ /h	(1450 n ⁻¹)

Tipo di lubrificante	Y = POE (estere di polioli)
Lubricant	Y = POE (polyol ester)
Huile lubrifiante	Y = POE (ester de poly huile)
Schmiermittel	Y = POE (Polyolesteröl)

FCAT01-07

- **FRASCOLD SpA** si riserva il diritto di modificare i dati e le caratteristiche contenute nel presente catalogo, senza obbligo di preavviso.
- **FRASCOLD SpA** reserves the right to change at any time, specifications or design without notice and without incurring obligations.
- **FRASCOLD SpA** se réserve le droit de modifier sans préavis les données et les caractéristiques contenues dans cette notice.
- **FRASCOLD SpA** behält sich das Recht vor Spezifikationen oder Ausführungen jederzeit ohne Bekanntgabe zu ändern.

Ref: **FCAT01-07**Edizione: **Febbraio 2004**

sostituisce: FCAT01-06

Febbraio 2003

Realizzazione: FRASCOLD SpA

Compressori semiermetici

Dotazione standard

I compressori sono forniti completi di rubinetti di aspirazione e compressione (attacchi a saldare), supporti antivibranti in gomma, carica olio lubrificante, carica di azoto (1 bar) per preservarli dalla umidità, indicatore di livello olio, dispositivi di protezione.

I compressori serie V, Z e W sono equipaggiati con pompa di lubrificazione e staffa universale per il montaggio del pressostato differenziale olio.

La dotazione standard può essere completata con una vasta gamma di accessori idonei a garantire efficienza e affidabilità a tutte le condizioni di funzionamento previste.

Tutti i modelli sono verniciati con uno strato di protettivo antiruggine e uno strato di smalto blu.

Motori elettrici

L'intera gamma di motori elettrici disponibili e le loro caratteristiche elettriche sono illustrate alla pagina 26 "Dati elettrici".

Tutti i modelli possono essere richiesti in versione 60Hz.

Per voltaggi diversi consultare il nostro Ufficio Tecnico.

Protezione del compressore

Tutti i compressori vengono forniti completi di protezione costituita da una catena di termistori PTC inseriti nello statore del motore elettrico e collegati al modulo elettronico di controllo (KRIWAN INT69 per i compressori serie A, B, C, D, F, Q e S; KRIWAN INT 69 TM per i compressori serie V, Z e W).

I compressori serie V, Z e W sono inoltre dotati di un sensore a termistore sullo scarico, collegato al modulo elettronico per il controllo della temperatura di compressione.

Per i compressori serie Q ed S il sensore a termistore è fornito a richiesta.

Lubrificazione

I compressori serie A, B, C, D, F, Q e S sono lubrificati mediante disco centrifugatore dell'olio. Nei compressori serie V, Z, W, la lubrificazione avviene per mezzo di pompa olio ad alta pressione e sono completi di filtro olio, di attacchi per il rilievo della pressione del lubrificante e staffa universale per il montaggio del pressostato differenziale.

Accessori

FRASCOLD ha selezionato e messo a punto una serie completa di accessori per i suoi compressori idonei a garantire efficienza e affidabilità a tutte le condizioni di funzionamento previste.

L'intera gamma di equipaggiamenti accessori disponibili è illustrata a pagina 35.

Semi-hermetic compressors

Standard equipment

The compressors are supplied with suction and discharge valves (sweat connections), rubber vibration absorbers, oil lubrication charge, nitrogen charge (1 bar) to protect compressor against humidity, oil sight glass and protection devices.

V, Z and W series are equipped with oil pump and universal bracket suitable for oil pressure switch mounting.

On request, compressor can be completed with a large range of optional equipments suitable for efficient and reliable functioning at every operative condition.

Compressors are coated with anti-rust protective primer and blue enamel coat.

Electric motors

Page 26 "Electric data" features the electric characteristics and performances of the whole range of available motors.

All models are also available with 60Hz electric motor.

For different voltages, please contact our Technical Department.

Protection devices

For all compressors, protection is performed by means a series of PTC thermistors placed into the stator winding of the electric motor and plugged to an electronic control module (KRIWAN INT69 for A, B, C, D, F, Q and S compressors and model KRIWAN INT 69 TM for V, Z and W compressors).

V, Z and W series compressors are supplied with discharge gas high temperature protection composed of a PTC thermistor sensor plugged to the electronic control module.

PTC thermistor sensor is supplied on request for Q and S series compressors.

Lubrication

For compressors of A, B, C, D, F, Q and S series, lubrication is carried out by centrifugation with an oil thrower disc.

V, Z and W series compressors lubrication is performed by an high pressure oil pump and equipment includes oil filter, oil pressure connection and universal bracket for oil pressure switch mounting.

Optional equipments

FRASCOLD has selected and developed a complete range of accessories to equip, on request, the compressor for an efficient and reliable running at every operating condition.

The whole range of available optional equipments is featured on page 35.

Compresseurs semi-hermétiques

Dotation standard

Les compresseurs sont entièrement équipés de soupapes d'aspiration et de refoulement (raccords à souder), supports anti-vibrations en caoutchouc, remplis d'huile lubrifiante, charge d'azote (1 bar) pour les préserver de l'humidité, indicateur de niveau d'huile, dispositifs de protection.

Les compresseurs série V, Z et W sont équipés de pompe de lubrification et bride universelle pour monter le pressostat d'huile.

La dotation standard peut être complétée par une vaste gamme d'accessoires propres à garantir rendement et fiabilité à tous les conditions de fonctionnement prévues.

Tous les modèles sont vernis par une couche d'antirouille et par une couche de peinture en émail bleu.

Moteurs électriques

Toute la gamme des moteurs électriques disponibles et leurs caractéristiques électriques sont illustrés à la page 26 "Données électriques".

Tous les modèles peuvent être demander en version 60 Hz.

Pour d'autres voltages, consulter notre service technique.

Protection du compresseur

Les compresseurs avec moteur triphasé sont entièrement fournis de protection constitué d'une série de thermistors PTC introduits dans le stator du moteur électrique et branchés au module électronique de commande (KRIWAN INT69 pour les compresseurs série A, B, C, D, F, Q et S; KRIWAN INT 69 TM pour les compresseurs série V, Z et W).

Les compresseurs série V, Z et W sont aussi équipés par un capteur à thermistor sur le refoulement, il est relié au module électronique pour la commande de la température de compression.

Pour les compresseurs série Q et S le capteur à thermisteur est fourni sur demande.

Graissage

Sur les séries A, B, C, D, F, Q et S le graissage se fait par centrifugation.

Sur les séries V, Z et W le graissage s'effectue par pompe à huile à haute pression.

Les compresseurs lubrifiés par pompe à huile sont pourvus de filtre à huile et de raccords pour le contrôle de la pression de l'huile.

Accessoires

FRASCOLD a sélectionné et mis au point, pour ses compresseurs, une série complète d'accessoires propres à garantir l'efficacité et la fiabilité à toutes les conditions d'application prévues.

Toute la gamme d'accessoires disponible est illustré à la page 35.

Halbhermetische Verdichter

Standardausrüstung

Die Verdichter werden komplett mit folgenden Teilen geliefert: Saug- und Druckventil (Lötanschlüsse), Schwingungsdämpfer, Schmierölfüllung, Schutzgasfüllung (1 bar) um sie vor Feuchtigkeit zu schützen, Ölschauglas und Motorschutzrelais.

Die Modelle V, Z, W besitzen einer Schmierpumpe und Universalsbügel für die Montage des Öldruckschalters.

Die Standardausrüstung kann mit einer großen Zubehörreihe komplettiert werden, die Wirkungsgrad und Sicherheit in jeder Betriebsbedingung gewährleisten.

Die Verdichter sind mit eine Zweischichtlackierung (Rostschutz und Deckschicht) lackiert.

Elektromotoren

Seite 26 "Elektrische Daten" illustriert die ganze Reihe der verfügbaren Motoren mit den elektrischen Eigenschaften.

Alle Modelle sind auch für 60 Hz lieferbar. Für andere Spannungen fragen Sie bitte unser technisches Büro.

Elektrischer Schutz

Alle Verdichter erfolgt der Schutz durch einer PTC Thermistorenreihe, in dem Stator der elektrischen Motor gestellt und zum elektronischen Auslösegerät verbunden (KRIWAN INT69 für A, B, C, D, F, Q, S; KRIWAN INT 69 TM für V, Z, W).

Die V, Z und W Verdichter sind komplett mit Thermistorsfühler, zum elektronischen Auslösegerät für Drucktemperaturregelung verbunden.

Für Q und S Verdichter wird der Thermistorsfühler auf Anfrage geliefert.

Schmierung

In den Baureihen A, B, C, D, F, Q, S erfolgt die Schmierung per Ölschleuder.

In den Baureihen V, Z, W erfolgt die Schmierung per Hochdruckölpumpe.

Die mit Ölpumpe geschmierten Verdichter sind mit Ölfilter, Anschlüssen für den Oldifferenzdruckschalter und Universalsbügel für die Montage des Öldruckschalters versehen.

Zubehöre

FRASCOLD hat eine komplette Zubehörreihe ausgewählt und eingestellt, die Wirkungsgrad und Sicherheit in jeder Betriebsbedingung gewährleisten.

Die komplette verfügbare Zubehörreihe ist auf Seite 35 illustriert.

Capacità frigorifere

Le capacità frigorifere, riportate nelle tabelle da pagina 6 a pagina 21, sono state calcolate alle seguenti condizioni:

- alimentazione 50Hz
- senza sottoraffreddamento del liquido
- temperatura ambiente 32°C
- **temperatura del gas aspirato 20°C**

R407C - Le temperature di evaporazione e di condensazione considerate sono relative al vapore saturo, in conformità con la norma EN12900.

Refrigerating capacity

Refrigerating capacities shown in page 6 up to page 21 are based on the following conditions:

- power supply 50Hz
- without liquid subcooling
- ambient temperature 32°C
- **suction gas temperature 20°C**

R407C - Evaporating and condensing temperatures are based on dew temperature, according to EN12900 standard.

Puissances frigorifiques

Les puissances frigorifiques, reportées sur les tableaux de la page 6 à la page 21, ont été calculées selon les conditions suivantes:

- alimentation 50Hz
- sans sous-refroidissement du liquide
- température ambiante 32°C
- **température du gaz aspiré 20°C**

R407C - les températures d'évaporation et de condensation se réfèrent au point de rosée, en conformité avec la norme EN12900.

Kälteleistungsdaten

Die auf den Seiten 6 bis 21 gezeigten Kälteleistungen basieren auf den folgenden Bedingungen:

- Netz 50Hz
- ohne Flüssigkeitsunterkühlung
- Umgebungstemperatur 32°C
- **Sauggastemperatur 20°C**

R407C - Verdampfungs- und Verflüssigungstemperaturen beziehen sich auf Taupunkt-Werte, erfüllen die Forderung EN12900.

Fattori di conversione

Conversion factors

Facteurs de correction

Umrechnungsfaktoren

Refrigerante	Refrigerant				Réfrigérant				Kältemittel				R507A	
Temperatura di condensazione Condensing temperature Température de condensation Verflüssigungstemperatur	Temperatura di evaporazione °C				Evaporating temperature °C				Température d'évaporation °C					Verdampfungstemperatur °C
	12.5	7.5	5	0	-5	-10	-15	-20	-25	-30	-35	-40	-45	
	Fattore di correzione				Conversion factor				Facteur de correction				Umrechnungsfaktor	
30°C					1.02	1.02	1.02	1.03	1.03	1.03	1.03	1.03	1.03	1.03
40°C					1.02	1.03	1.03	1.03	1.04	1.04	1.04	1.04	1.04	1.04
45°C					1.03	1.03	1.04	1.04	1.04	1.04	1.04	1.04	1.04	1.04
50°C					1.03	1.04	1.04	1.04	1.04	1.04	1.05	1.05	1.05	1.05

I valori di capacità frigorifera possono essere calcolati moltiplicando i dati delle tabelle da pagina 6 a pagina 9 per il fattore relativo alle temperature di evaporazione e condensazione considerate; esempio:

compressore modello D 3 18 Y
refrigerante R507A

temp. di evaporazione -25°C
temp. di condensazione 50°C

resa frigorifera 4120 W
fattore di correzione 1.04

resa frigorifera corretta:
4120 x 1.04 = 4285 W

To calculate actual refrigerating capacity, multiply capacity table value (see page 6 up to page 9) by proper conversion factor related to considered condensing and evaporating temperatures; example:

compressor model D 3 18 Y
refrigerant R507A

evaporating temperature -25°C
condensing temperature 50°C

refrigerating capacity 4120 W
conversion factor 1.04

actual refrigerating capacity:
4120 x 1.04 = 4285 W

Les valeurs de puissance frigorifique peuvent être calculées en multipliant les données des tableaux de la page 6 à la page 9 par le facteur concernant les températures d'évaporation et de condensation considérées; par exemple:

compresseur modèle D 3 18 Y
réfrigérant R507A

temp. d'évaporation -25°C
temp. de condensation 50°C

puissance frigorifique 4120 W
facteur de correction 1.04

puissance frigorifique correcte:
4120 x 1.04 = 4285 W

Die Leistungswerte errechnen sich durch Multiplikation der Daten der Tabellen von Seite 6 bis Seite 9 mit den Umrechnungsfaktoren; Beispiel:

Verdichter Modell D 3 18 Y
Kältemittel R507A

Verdampfungstemperatur -25°C
Verflüssigungstemperatur 50°C

Kälteleistung 4120 W
Korrekturfaktor 1.04

aktuelle Kälteleistung:
4120 x 1.04 = 4285 W

Refrigerante	Refrigerant				Réfrigérant				Kältemittel				R22	
Temperatura di condensazione Condensing temperature Température de condensation Verflüssigungstemperatur	Temperatura di evaporazione °C				Evaporating temperature °C				Température d'évaporation °C					Verdampfungstemperatur °C
	12.5	7.5	5	0	-5	-10	-15	-20	-25	-30	-35	-40	-45	
	Fattore di correzione				Conversion factor				Facteur de correction				Umrechnungsfaktor	
30°C											0.911	0.890	0.871	
40°C										0.927	0.896	0.875	0.857	
45°C									0.940	0.927	0.908	0.892	0.871	0.852
50°C									0.940	0.924	0.905	0.888	0.846	0.846

I valori di capacità frigorifera durante l'iniezione di liquido possono essere calcolati moltiplicando i dati delle tabelle da pagina 16 a pagina 17 per il fattore relativo alle temperature di evaporazione e condensazione considerate; esempio:

compressore modello S 7 39 Y
refrigerante R22

temp. di evaporazione -30°C
temp. di condensazione 50°C

resa frigorifera 6030 W
fattore di correzione 0.905

resa frigorifera corretta:
6030 x 0.905 = 5457 W

To calculate actual refrigerating capacity during liquid injection, multiply capacity table value (see page 16 and page 17) by proper conversion factor related to considered condensing and evaporating temperatures.

Example:
compressor model S 7 39 Y
refrigerant R22

evaporating temperature -30°C
condensing temperature 50°C

refrigerating capacity 6030 W
conversion factor 0.905

actual refrigerating capacity:
6030 x 0.905 = 5457 W

Les valeurs de puissance frigorifique pendant l'injection de liquide peuvent être calculées en multipliant les données des tableaux de la page 16 à la page 17 par le facteur concernant les températures d'évaporation et de condensation considérées; par exemple:

compresseur modèle S 7 39 Y
réfrigérant R22

temp. d'évaporation -30°C
temp. de condensation 50°C

puissance frigorifique 6030 W
facteur de correction 0.905

puissance frigorifique correcte:
6030 x 0.905 = 5457 W

Um die aktuelle Kälteleistung bei gleichzeitiger Flüssigkeits-einspritzung zu kalkulieren ist die Leistungszahl in der Tabelle (von Seite 16 bis Seite 17) mit dem richtigen Korrekturfaktor entsprechend den Verflüssigungs- bzw. Verdampfungstemperaturen zu multiplizieren;

Beispiel:
Verdichter Modell S 7 39 Y
Kältemittel R22

Verdampfungstemperatur -30°C
Verflüssigungstemperatur 50°C

Kälteleistung 6030 W
Korrekturfaktor 0.905

aktuelle Kälteleistung:
6030 x 0.905 = 5457 W

Tipi di lubrificante

Lubricant types

Type de lubrifiant

Schmieröltyp

Viscosità Viscosity Viscosité Viskosität	Carica con olio POE (estere di polioli) - Charge with POE (polyol ester) - Charge avec huile POE (ester de poly huile) - POE (Polyolesteröl) Ölfüllung	
cSt	carica originale factory charge charge originale Originalfüllung	lubrificanti approvati approved lubricants lubrifiant homologuée zugelassene Schmiermittel
32	FRASCOLD 32FC	ELF Planetelf ACD32 - ICI Emkarate RL 32 S

Dati tecnici

Technical data

Données techniques

Technische Daten

Compressore Compressor Compresseur Verdichter	Motore elettrico Electric motor Moteur électrique Elektromotor		Capacità volumetrica Displacement Volume balayé Hubvolumen (50 Hz)	nr	Cilindri Cylinders Cylindres Zylinder		Lubrificante Lubricant Lubrifiant Schmiermittel	Pesi Weights Poids Gewicht		Volume imballo Packing volume Volume emballage Verpackungsvolumen
	HP	kW			alesaggio bore alésage Bohrung mm	corsa stroke course Hub mm		netto net Netto kg	lordo gross brut Brutto kg	
A 0.5 4 Y	0.5	0.37	3.95	2	34	25	1.2	36	37	37
A 0.5 5 Y	0.5	0.37	4.93	2	38	25	1.2	36	37	37
A 0.7 5 Y	0.75	0.55	4.93	2	38	25	1.2	36	37	37
A 0.7 6 Y	0.75	0.55	5.47	2	40	25	1.2	36	37	37
A 1 6 Y	1	0.75	5.47	2	40	25	1.2	36	37	37
A 1 7 Y	1	0.75	6.91	2	38	35	1.2	36	37	37
A 1.5 7 Y	1.5	1.10	6.91	2	38	35	1.2	36	37	37
A 1.5 8 Y	1.5	1.10	7.65	2	40	35	1.2	36	37	37
B 1.5 9 Y	1.5	1.10	8.96	2	40	41	1.2	38	39	37
B 1.5 10 Y	1.5	1.10	9.84	2	40	45	1.2	38	39	37
B 2 10 Y	2	1.50	9.84	2	40	45	1.2	40	41	37
C 2 11 Y	2	1.50	10.93	2	40	50	1.2	40	41	37
D 2 11 Y	2	1.50	11.26	2	50	33	1.2	45	46	47
C 2 12 Y	2	1.50	12.05	2	42	50	1.2	40	41	37
C 3 12 Y	3	2.20	12.05	2	42	50	1.2	40	41	37
D 2 13 Y	2	1.50	13.84	2	54	33	1.2	45	46	47
D 3 13 Y	3	2.20	13.84	2	54	33	1.2	49	50	47
D 2 15 Y	2	1.50	15.36	2	50	45	1.2	45	46	47
D 3 15 Y	3	2.20	15.36	2	50	45	1.2	49	50	47
D 3 16 Y	3	2.20	16.39	2	50	48	1.2	49	50	47
D 4 16 Y	4	3.00	16.39	2	50	48	1.2	51	52	47
F 4 16 Y	4	3.00	16.39	2	50	48	2.1	74	77	76
D 3 18 Y	3	2.20	17.93	2	54	45	1.2	49	50	47
D 4 18 Y	4	3.00	17.93	2	54	45	1.2	51	52	47
D 3 19 Y	3	2.20	19.12	2	54	48	1.2	49	50	47
F 4 19 Y	4	3.00	19.12	2	54	48	2.1	74	77	76
F 5 19 Y	5	3.70	19.12	2	54	48	2.1	76	79	76
F 4 24 Y	4	3.00	23.60	2	60	48	2.1	74	77	76
F 5 24 Y	5	3.70	23.60	2	60	48	2.1	76	79	76
Q 4 25 Y	4	3.00	24.69	4	54	31	1.8	77	80	76
F 5 25 Y	5	3.70	25.21	2	62	48	2.1	76	79	76
Q 5 25 Y	5	3.70	24.69	4	54	31	1.8	79	82	76
Q 7 25 Y	7.5	5.50	24.69	4	54	31	1.8	79	82	76
Q 5 28 Y	5	3.70	27.88	4	54	35	1.8	79	82	76
Q 7 28 Y	7.5	5.50	27.88	4	54	35	1.8	79	82	76
Q 5 33 Y	5	3.70	32.66	4	54	41	1.8	79	82	76
S 5 33 Y	5.5	4.00	32.80	4	50	48	3.3	115	129	201
Q 7 33 Y	7.5	5.50	32.66	4	54	41	1.8	79	82	76
S 7 33 Y	7.5	5.50	32.80	4	50	48	3.3	117	131	201
S 7 39 Y	7.5	5.50	38.25	4	54	48	3.3	117	131	201
S 10 39 Y	10	7.50	38.25	4	54	48	3.3	120	134	201
S 10 51 Y	10	7.50	50.43	4	62	48	3.3	120	134	201
S 15 51 Y	15	11.00	50.43	4	62	48	3.3	126	140	201
S 15 56 Y	15	11.00	56.00	4	64	50	3.3	130	144	201
S 20 56 Y	20	15.00	56.00	4	64	50	3.3	132	146	201
V 15 59 Y	15	11.00	58.48	4	62	56	4.5	170	184	285
V 20 59 Y	20	15.00	58.48	4	62	56	4.5	174	188	285
V 15 71 Y	15	11.00	70.77	4	68	56	4.5	170	184	285
V 25 71 Y	25	18.50	70.77	4	68	56	4.5	184	198	285
V 20 84 Y	20	15.00	83.81	4	74	56	4.5	180	194	285
V 30 84 Y	30	22.00	83.81	4	74	56	4.5	187	201	285
V 25 93 Y	25	18.50	93.05	4	78	56	4.5	190	204	285
V 32 93 Y	32	23.50	93.05	4	78	56	4.5	192	206	285
V 25 103 Y	25	18.50	102.90	4	82	56	4.5	190	204	285
V 35 103 Y	35	26.00	102.90	4	82	56	4.5	193	207	285
Z 25 106 Y	25	18.50	106.16	6	68	56	4.5	220	242	355
Z 35 106 Y	35	26.00	106.16	6	68	56	4.5	223	245	355
Z 30 126 Y	30	22.00	125.72	6	74	56	7.5	229	251	355
Z 40 126 Y	40	30.00	125.72	6	74	56	7.5	240	262	355
W 40 142 Y	40	30.00	141.50	8	68	56	8.0	295	320	450
Z 40 154 Y	40	30.00	154.38	6	82	56	7.5	240	262	355
Z 50 154 Y	50	37.00	154.38	6	82	56	7.5	244	266	355
W 40 168 Y	40	30.00	167.60	8	74	56	8.0	299	325	450
W 50 168 Y	50	37.00	167.60	8	74	56	8.0	305	331	450
W 50 187 Y	50	37.00	186.10	8	78	56	8.0	311	337	450
W 60 187 Y	60	44.50	186.10	8	78	56	8.0	315	341	450
W 60 206 Y	60	44.50	205.80	8	82	56	8.0	320	346	450
W 70 206 Y	70	52.00	205.80	8	82	56	8.0	328	354	450
W 70 228 Y	70	52.00	227.77	8	82	62	8.0	328	354	450
W 75 228 Y	75	55.50	227.77	8	82	62	8.0	328	354	450
W 75 240 Y	75	55.50	239.02	8	84	62	8.0	328	354	450
W 80 240 Y	80	60.00	239.02	8	84	62	8.0	328	354	450

Capacità frigorifere

Refrigerating capacity

Puissances frigorifiques

Kälteleistungsdaten

Compressore Compressor Compresseur Verdichter	Condensazione Condensing Condensation Verflüssigungs- temperatur °C	R404A - R507A*												
		Capacità frigorifera W			Refrigerating capacity W			Puissances frigorifiques W			Kälteleistungsdaten W			
		Temperatura di evaporazione °C			Evaporating temperature °C			Température d'évaporation °C			Verdampfungstemperatur °C			
		7.5	5	0	-5	-10	-15	-20	-25	-30	-35	-40	-45	
A 0.5 4 Y	30	4800	4400	3690	3070	2530	2070	1660	1320	1020	760	550		
	40	4090	3750	3150	2620	2150	1750	1390	1090	820	600	400		
	45	3730	3420	2870	2390	1960	1590	1260	970	720	510	330		
	50	3370	3100	2600	2160	1770	1420	1120	860	630	430	260		
A 0.5 5 Y	30				3730	3080	2520	2030	1610	1240	930	670	450	
	40				3170	2610	2130	1700	1330	1010	730	500	300	
	45				2890	2380	1930	1530	1190	890	630	410	220	
	50				2600	2140	1730	1370	1050	770	530	330		
A 0.7 5 Y	30		5340	4470	3730	3080	2520	2030	1610	1240	930	670	450	
	40		4520	3800	3170	2610	2130	1700	1330	1010	730	500	300	
	45		4120	3460	2890	2380	1930	1530	1190	890	630	410	220	
	50			3130	2600	2140	1730	1370	1050	770	530	330		
A 0.7 6 Y	30				4090	3390	2770	2240	1770	1370	1030	740	500	
	40				3470	2870	2340	1870	1460	1110	810	550	330	
	45				3160	2610	2120	1690	1310	980	700	450	250	
	50				2850	2350	1900	1500	1150	850	590	360	170	
A 1 6 Y	30		6540	6000	5020	4180	3450	2820	2270	1790	1390	1040	740	500
	40		5570	5110	4290	3560	2930	2380	1900	1480	1120	810	550	330
	45		5080	4670	3910	3250	2670	2160	1710	1330	990	700	460	250
	50		4590	4220	3540	2940	2410	1940	1530	1170	860	590	360	
A 1 7 Y	30				5180	4290	3510	2830	2240	1740	1300	940	630	
	40				4390	3630	2960	2370	1850	1400	1020	690	420	
	45				4000	3300	2680	2130	1650	1240	880	570	310	
	50				3600	2970	2400	1900	1460	1070	740	460		
A 1.5 7 Y	30		8370	7670	6420	5330	4400	3590	2880	2280	1760	1320	940	
	40		7170	6580	5500	4560	3740	3030	2410	1880	1420	1030	700	
	45		6560	6020	5030	4160	3410	2750	2180	1680	1250	890	580	
	50		5940	5450	4560	3770	3080	2470	1940	1480	1090	750	460	
A 1.5 8 Y	30			8500	7110	5910	4870	3970	3190	2520	1950	1450	1040	690
	40			7250	6070	5040	4140	3350	2670	2080	1570	1130	760	450
	45			6630	5550	4600	3770	3040	2410	1860	1380	970	630	330
	50			6000	5020	4160	3400	2730	2140	1630	1190	810	490	
B 1.5 9 Y	30				8190	6820	5630	4590	3700	2930	2270	1710	1230	830
	40				6980	5810	4780	3890	3100	2430	1850	1350	920	570
	45				6370	5300	4350	3530	2800	2170	1630	1170	770	430
	50				5770	4790	3930	3170	2500	1920	1420	990	620	
B 1.5 10 Y	30					6510	5330	4310	3430	2670	2030	1480	1020	
	40					5530	4510	3620	2850	2180	1610	1130	720	
	45					5040	4100	3280	2560	1940	1410	960	570	
	50					4540	3680	2930	2270	1700	1210	790		
B 2 10 Y	30		12210	11180	9360	7770	6410	5230	4220	3340	2600	1960		
	40		10400	9530	7970	6620	5440	4420	3540	2770	2120	1560		
	45		9450	8670	7270	6030	4950	4010	3190	2480	1870	1350		
	50		8500	7800	6540	5430	4460	3600	2850	2200	1630	1150		
C 2 11 Y	30		13840	12680	10610	8810	7260	5930	4770	3780	2930	2210	1600	
	40		11850	10860	9080	7530	6190	5020	4010	3140	2390	1750	1220	
	45		10830	9930	8300	6880	5640	4560	3630	2820	2120	1530	1020	
	50		9820	9000	7530	6220	5090	4100	3240	2490	1850	1300	830	
D 2 11 Y	30		13400	12280	10280	8550	7060	5760	4650	3700	2870	2160	1560	
	40		11410	10470	8780	7290	6000	4880	3900	3060	2330	1710	1170	
	45		10370	9530	8010	6600	5470	4430	3520	2740	2060	1480	980	
	50		9350	8600	7230	6020	4930	3980	3150	2420	1790	1250	790	
C 2 12 Y	30					9210	7590	6200	4990	3960	3070	2310	1670	1130
	40					7840	6460	5260	4210	3310	2530	1870	1310	830
	45					7180	5900	4780	3810	2980	2250	1630	1110	
	50					6460	5310	4300	3430	2670	2010	1450	970	
C 3 12 Y	30		14600	13380	11190	9300	7660	6250	5030	3980	3080	2320		
	40		12430	11400	9550	7930	6520	5300	4240	3320	2540	1870		
	45		11340	10410	8720	7240	5950	4820	3850	3000	2270	1650		
	50		10240	9410	7890	6550	5370	4350	3450	2680	2010	1440		
D 2 13 Y	30					10250	8470	6940	5610	4470	3490	2650	1930	1330
	40					8700	7210	5880	4720	3710	2850	2110	1470	930
	45					7920	6550	5350	4270	3340	2530	1840	1240	740
	50					7140	5910	4810	3820	2960	2210	1570	1020	
D 3 13 Y	30		16230	14870	12440	10350	8530	6970	5620	4460	3460			
	40		13840	12690	10630	8830	7270	5910	4720	3700	2820			
	45		12640	11600	9720	8070	6630	5370	4270	3320	2500			
	50		11440	10500	8800	7300	5980	4830	3810	2940	2180			
D 2 15 Y	30						9330	7680	6250	5020	3960	3060	2300	1660
	40						7930	6540	5310	4230	3300	2510	1840	1260
	45						7230	5950	4830	3840	2970	2230	1600	1070
	50						5370	4350	3440	2640	2010	1450	1070	880

Con raffreddamento della testata
With head cooling
Avec refroidissement de la tête
Mit Zylinderkopfkühlung

* R507A capacità frigorifera da calcolare come indicato a pagina 4
refrigerating capacities to be calculated as indicated on page 4
puissances frigorifiques à calculer comme indiqué à la page 4
Kälteleistungen zu rechnen wie auf Seite 4 gezeigt

Capacità frigorifere

Refrigerating capacity

Puissances frigorifiques

Kälteleistungsdaten

Compressore Compressor Compresseur Verdichter	Condensazione Condensing Condensation Verflüssigungs- temperatur °C	R404A - R507A*												
		Capacità frigorifera W			Refrigerating capacity W				Puissances frigorifiques W			Kälteleistungsdaten W		
		Temperatura di evaporazione °C			Evaporating temperature °C				Température d'évaporation °C			Verdampfungstemperatur °C		
		7.5	5	0	-5	-10	-15	-20	-25	-30	-35	-40	-45	
D 3 15 Y	30	17800	16310	13670	11380	9410	7700	6230	4970	3890	2960	2180	1530	
	40	15200	13940	11690	9740	8030	6550	5270	4160	3200	2390	1700	1120	
	45	13890	12750	10700	8900	7340	5970	4780	3750	2860	2100	1460	910	
	50	12560	11550	9690	8060	6640	5380	4290	3340	2520	1820	1220		
D 3 16 Y	30				12270	10190	8380	6830	5480	4330	3350	2510	1810	
	40				10530	8730	7170	5820	4630	3620	2750	2010	1390	
	45				9640	8000	6560	5300	4210	3260	2450	1760	1180	
	50				8740	7260	5940	4790	3780	2900	2160	1520	970	
D 4 16 Y	30	19450	17850	14990	12520	10380	8530	6940	5570	4390				
	40	16690	15330	12900	10780	8920	7310	5920	4710	3670				
	45	15270	14050	11830	9890	8190	6690	5400	4280	3310				
	50	13860	12750	10750	8980	7430	6070	4880	3840	2950				
F 4 16 Y	30	19900	18260	15320	12780	10570	8670	7020	5600	4390				
	40	17130	15730	13200	11000	9080	7420	5970	4720	3650				
	45	15740	14460	12120	10090	8320	6780	5440	4270	3270				
	50	14300	13140	11040	9170	7550	6130	4890	3820	2890				
D 3 18 Y	30				13360	11090	9130	7440	5970	4720	3650	2740	1980	
	40				11460	9510	7810	6330	5050	3950	3000	2200	1520	
	45				10490	8710	7140	5780	4590	3560	2680	1930	1300	
	50				9510	7890	6470	5210	4120	3170	2360	1660	1080	
D 4 18 Y	30	21200	19450	16320	13620	11290	9280	7540	6050	4770				
	40	18160	16680	14020	11710	9700	7950	6430	5120	4000				
	45	16600	15260	12480	10720	8880	7270	5860	4650	3600				
	50	15030	13830	11650	9730	8050	6580	5300	4170	3210				
D 3 19 Y	30				11850	9800	8020	6490	5180	4060	3110	2310		
	40				10170	8420	6880	5540	4390	3410	2570	1860		
	45				9320	7710	6300	5060	4000	3080	2300	1640		
	50				8460	7000	5710	4580	3600	2750	2030			
F 4 19 Y	30		21510	18070	15100	12530	10310	8400	6750	5330	4130	3110	2260	
	40		18550	15610	13030	10810	8870	7190	5740	4490	3420	2520	1760	
	45		17020	14340	11990	9930	8130	6570	5220	4060	3070	2220	1520	
	50		15470	13050	10910	9040	7380	5950	4700	3630	2710	1930		
F 5 19 Y	30	23730	21790	18280	15240	12620	10340	8390	6710	5270				
	40	20450	18780	15770	13150	10870	8890	7160	5680	4410				
	45	18780	17250	14480	12070	9970	8140	6540	5150	3970				
	50	17070	15690	13190	10980	9060	7370	5900	4620	3530				
F 4 24 Y	30				18580	15420	12700	10360	8340	6610	5140	3900	2850	
	40				15990	13290	10930	8880	7100	5580	4280	3180	2250	
	45				14670	12190	10020	8120	6470	5060	3840	2820	1950	
	50				11080	9100	7360	5840	4530	3410	2450			
F 5 24 Y	30		26660	22393	18710	15530	12780	10410	8350	6590	5100	3850	2790	
	40		22930	19310	16140	13370	10980	8900	7110	5550	4230	3120	2180	
	45		21010	17710	14820	12280	10060	8140	6470	5020	3790	2750	1880	
	50		19070	16100	13470	11170	9140	7360	5820	4490	3350	2380		
Q 4 25 Y	30				16090	13160	10630	8450	6580	4980	3630	2490		
	40				13680	11160	8950	7030	5380	3960	2760	1740		
	45				12470	10150	8110	6320	4780	3450	2330	1380		
	50				9130	7250	5600	4180	2950	1900				
F 5 25 Y	30				19870	16510	13610	11110	8940	7100	5530	4210	3100	
	40				17160	14250	11720	9540	7650	6030	4640	3470	2480	
	45				15760	13100	10770	8740	6990	5490	4190	3090	2170	
	50				14340	11920	9790	7930	6320	4930	3730	2720		
Q 5 25 Y	30				19290	16030	13210	10790	8710	6930	5410	4120	3040	
	40				16620	13810	11370	9260	7430	5870	4530	3390	2430	
	45				15260	12680	10440	8480	6780	5330	4080	3020	2130	
	50				13900	11540	9480	7690	6130	4790	3640	2660		
Q 7 25 Y	30	30300	27570	23210	19430	16210	13370	10940	8840	7080				
	40	26210	24060	20240	16910	14090	11580	9430	7570	6010				
	45	24190	22210	18680	15600	12970	10640	8650	6910	5460				
	50	21960	20160	16950	14150	11750	9620	7790	6210	4870				
Q 5 28 Y	30				21850	18180	15000	12260	9910	7880	6150	4690	3470	
	40				18790	15660	12930	10540	8470	6690	5170	3870	2780	
	45				17220	14370	11860	9660	7740	6090	4670	3460	2440	
	50				13070	10780	8770	7000	5480	4170	3040			
Q 7 28 Y	30	34990	32060	26830	22320	18390	15000	12080	9570	7420				
	40	30010	27520	23020	19100	15690	12740	10170	7950	6050				
	45	27490	25210	21090	17470	14320	11580	9200	7130	5360				
	50	24970	22900	19120	15820	12940	10410	8220	6310	4670				
Q 5 33 Y	30				24490	20340	16740	13620	10950	8650	6680	5010	3610	
	40				20890	17380	14300	11610	9260	7240	5500	4020	2780	
	45					15870	13060	10590	8410	6530	4910	3530	2370	
	50						11820	9550	7550	5810	4320	3040	1960	

Con raffreddamento della testata
With head cooling
Avec refroidissement de la tête
Mit Zylinderkopfkühlung

*R507A capacità frigorifera da calcolare come indicato a pagina 4
refrigerating capacities to be calculated as indicated on page 4
puissances frigorifiques à calculer comme indiqué à la page 4
Kälteleistungen zu rechnen wie auf Seite 4 gezeigt

Capacità frigorifere

Refrigerating capacity

Puissances frigorifiques

Kälteleistungsdaten

Compressore Compressor Compresseur Verdichter	Condensazione Condensing Condensation Verflüssigungs- temperatur °C	R404A - R507A*											
		Capacità frigorifera W			Refrigerating capacity W			Puissances frigorifiques W			Kälteleistungsdaten W		
		Temperatura di evaporazione °C			Evaporating temperature °C			Température d'évaporation °C			Verdampfungstemperatur °C		
		7.5	5	0	-5	-10	-15	-20	-25	-30	-35	-40	-45
S 5 33 Y	30				21580	17730	14420	11560	9130	7060	5300	3830	
	40				18510	15180	12280	9780	7630	5800	4260	2950	
	45				16920	13870	11210	8880	6880	5180	3730	2510	
	50					12540	10110	7970	6130	4550	3220		
Q 7 33 Y	30	38970	35750	30000	25030	20740	17030	13830	11090	8740			
	40	33560	30820	25880	21580	17850	14610	11810	9390	7320			
	45	30840	28330	23780	19820	16380	13380	10780	8540	6600			
	50			21660	18050	14880	12130	9740	7670	5880			
S 7 33 Y	30	40290	36940	30950	25780	21300	17430	14090	11210	8750			
	40	34560	31710	26560	22100	18230	14850	11930	9390	7220			
	45	31640	29050	24360	20250	16660	13540	10830	8470	6450			
	50		26350	22110	18370	15080	12210	9720	7550	5670			
S 7 39 Y	30				30150	25050	20640	16840	13550	10740	8340	6320	4620
	40				26020	21610	17750	14430	11550	9070	6950	5160	3650
	45				23900	19840	16300	13200	10530	8220	6250	4570	3160
	50					18050	14800	11960	9490	7370	5540	3990	
S 10 39 Y	30	47070	43210	36290	30310	25140	20670	16800	13480	10630			
	40	40550	37260	31310	26150	21660	17750	14370	11440	8930			
	45	37220	34220	28800	24050	19880	16270	13130	10400	8060			
	50	33840	31130	26220	21890	18080	14760	11870	9360	7190			
S 10 51 Y	30				39490	32790	26960	21960	17630	13930	10770	8090	5840
	40				33930	28160	23130	18740	14940	11670	8880	6500	4500
	45					25810	21170	17120	13580	10530	7930	5710	3840
	50						19180	15460	12200	9390	6970	4920	
S 15 51 Y	30	61220	56160	47090	39260	32490	26640	21610	17250	13520			
	40	52580	48270	40460	33710	27830	22720	18280	14480	11190			
	45	48180	44260	37160	30920	25470	20740	16630	13070	10010			
	50	43700	40160	33750	28080	23070	18730	14940	11660	8830			
S 15 56 Y	30				44670	37020	30400	24690	19780	15560	11950	8890	6320
	40				38440	31760	25990	20980	16650	12940	9750	7030	4740
	45				35240	29120	23750	19100	15080	11610	8640	6100	3960
	50				31990	26420	21480	17210	13480	10290	7530	5180	
S 20 56 Y	30	69600	63830	53590	44710	37170	30500	24800	19860	15730			
	40	60490	55440	46480	38680	32040	26160	21120	16750	13100			
	45	55710	51050	42760	35530	29370	23910	19220	15160	11750			
	50	50440	46210	38680	32090	26470	21470	17180	13460	10330			
V 15 59 Y	30				46130	38370	31510	25630	20550	16300	12630	9580	6810
	40				39940	33100	27050	21860	17370	13610	10350	7640	5190
	45				36710	30370	24740	19920	15740	12230	9190	6670	4370
	50				33170	27380	22240	17820	13990	10770	7980	5660	
V 20 59 Y	30	72420	66450	55760	46480	38440	31480	25470	20290	15860			
	40	62220	57140	47960	39950	32970	26890	21610	17040	13120			
	45	57090	52440	43990	36630	30190	24560	19650	15390	11740			
	50	51860	47650	40010	33250	27360	22180	17660	13730	10350			
V 15 71 Y	30				54820	45490	37390	30360	24330	19160	14760	11020	7850
	40				46820	38860	31900	25810	20480	15930	12030	8720	5900
	45					35510	29110	23490	18540	14300	10670	7570	
	50						26300	21150	16590	12680	9310	6440	
V 25 71 Y	30	85740	78650	65960	54960	45450	37210	30100	23970	18740			
	40	73740	67700	56820	47300	39010	31800	25550	20140	15510			
	45	67670	62160	52130	43390	35730	29040	23240	18200	13880			
	50	61450	56470	47420	39400	32390	26240	20880	16240	12240			
V 20 84 Y	30				53720	44320	36230	29210	23200	18050	13690	10030	
	40				46300	38170	31070	24920	19620	15060	11190	7930	
	45				42530	35020	28430	22730	17790	13540	9930		
	50				31830	25800	20510	15950	12020		8670		
V 30 84 Y	30	102270	93880	78770	65780	54500	44730	36290	29030	22810			
	40	87900	80790	67960	56750	46950	38400	30970	24560	19060			
	45	80730	74240	62410	52110	43080	35160	28260	22280	17150			
	50	73400	67520	56850	47390	39130	31830	25500	19980	15230			
V 25 93 Y	30				71770	59730	49250	40200	32380	25680	19970	15130	11080
	40				61840	51490	42440	34510	27640	21730	16650	12360	8760
	45					47300	38940	31600	25210	19700	14980	10970	
	50				43040	35390	28640	22760	17660	13290	9570		
V 32 93 Y	30	112700	103460	86930	72630	60240	49470	40160	32140	25260			
	40	96700	88900	74830	62530	51760	42410	34250	27170	21090			
	45	88560	81510	68660	57370	47440	38800	31210	24640	18970			
	50		62420	52150	43100	35130	28190	22090	16850				
V 25 103 Y	30				65570	54150	44230	35650	28290	22010	16690	12220	
	40				56430	46570	37950	30410	23920	18360	13630	9660	
	45					42710	34730	27740	21960	16490	12090		
	50					38790	31480	25030	19450	14640	10550		

Con raffreddamento della testata
With head cooling
Avec refroidissement de la tête
Mit Zylinderkopfkühlung

* R507A

capacità frigorifera da calcolare come indicato a pagina 4
refrigerating capacities to be calculated as indicated on page 4
puissances frigorifiques à calculer comme indiqué à la page 4
Kälteleistungen zu rechnen wie auf Seite 4 gezeigt

Capacità frigorifere

Refrigerating capacity

Puissances frigorifiques

Kälteleistungsdaten

Compressore Compressor Compresseur Verdichter	Condensazione Condensing Condensation Verflüssigungs- temperatur °C	R407C								
		Capacità frigorifera W		Refrigerating capacity W			Puissances frigorifiques W		Kälteleistungsdaten W	
		Temperatura di evaporazione °C		Evaporating temperature °C			Température d'évaporation °C		Verdampfungstemperatur °C	
		12.5	7.5	5	0	-5	-10	-15	-20	-25
A 0.5 4 Y	30	5230	4340	3950	3250	2660	2150	1710	1340	1020
	40	4590	3810	3470	2850	2320	1860	1470	1130	850
	45	4260	3540	3220	2640	2140	1710	1340	1030	760
	50	3930	3270	2970	2430	1970	1560	1220	920	660
A 0.5 5 Y	30	A RICHIESTA		ON REQUEST			SUR DEMAND		AUF ANFRAGE	
	40	A RICHIESTA		ON REQUEST			SUR DEMAND		AUF ANFRAGE	
	45	A RICHIESTA		ON REQUEST			SUR DEMAND		AUF ANFRAGE	
	50	A RICHIESTA		ON REQUEST			SUR DEMAND		AUF ANFRAGE	
A 0.7 5 Y	30	6440	5350	4870	4010	3280	2650	2120	1660	1270
	40	5610	4670	4250	3500	2850	2300	1840	1400	1050
	45	5190	4320	3940	3240	2640	2110	1660	1270	940
	50	4780	3980	3620	2980	2410	1930	1500	1140	820
A 0.7 6 Y	30	A RICHIESTA		ON REQUEST			SUR DEMAND		AUF ANFRAGE	
	40	A RICHIESTA		ON REQUEST			SUR DEMAND		AUF ANFRAGE	
	45	A RICHIESTA		ON REQUEST			SUR DEMAND		AUF ANFRAGE	
	50	A RICHIESTA		ON REQUEST			SUR DEMAND		AUF ANFRAGE	
A 1 6 Y	30	7210	5990	5450	4490	3670	2960	2360	1850	1420
	40	6320	5250	4780	3930	3200	2570	2030	1570	1170
	45	5870	4880	4440	3650	2960	2360	1850	1420	1050
	50	5420	4500	4090	3350	2710	2160	1680	1270	920
A 1 7 Y	30	A RICHIESTA		ON REQUEST			SUR DEMAND		AUF ANFRAGE	
	40	A RICHIESTA		ON REQUEST			SUR DEMAND		AUF ANFRAGE	
	45	A RICHIESTA		ON REQUEST			SUR DEMAND		AUF ANFRAGE	
	50	A RICHIESTA		ON REQUEST			SUR DEMAND		AUF ANFRAGE	
A 1.5 7 Y	30	9180	7660	6970	5730	4670	3760	2980	2330	1780
	40	8090	6710	6100	5010	4070	3260	2570	1990	1490
	45	7540	6250	5680	4650	3770	3010	2360	1800	1330
	50	6970	5780	5250	4290	3460	2750	2130	1610	1170
A 1.5 8 Y	30	10120	8490	7650	6300	5140	4150	3310	2590	1990
	40	8910	7400	6730	5520	4490	3600	2840	2190	1640
	45	8290	6880	6260	5130	4150	3320	2600	1990	1470
	50	7660	6360	5780	4730	3820	3030	2360	1780	1290
B 1.5 9 Y	30	A RICHIESTA		ON REQUEST			SUR DEMAND		AUF ANFRAGE	
	40	A RICHIESTA		ON REQUEST			SUR DEMAND		AUF ANFRAGE	
	45	A RICHIESTA		ON REQUEST			SUR DEMAND		AUF ANFRAGE	
	50	A RICHIESTA		ON REQUEST			SUR DEMAND		AUF ANFRAGE	
B 1.5 10 Y	30	A RICHIESTA		ON REQUEST			SUR DEMAND		AUF ANFRAGE	
	40	A RICHIESTA		ON REQUEST			SUR DEMAND		AUF ANFRAGE	
	45	A RICHIESTA		ON REQUEST			SUR DEMAND		AUF ANFRAGE	
	50	A RICHIESTA		ON REQUEST			SUR DEMAND		AUF ANFRAGE	
B 2 10 Y	30	12940	10750	9780	8060	6580	5320	4240	3330	2550
	40	11350	9430	8580	7060	5740	4610	3640	2810	2110
	45	10520	8760	7970	6550	5310	4240	3330	2550	1880
	50	9670	8060	7340	6020	4870	3880	3020	2280	1650
C 2 11 Y	30	14680	12190	11090	9130	7450	6020	4790	3750	2870
	40	12930	10740	9760	8020	6510	5220	4120	3170	2370
	45	12050	10000	9080	7450	6030	4810	3770	2880	2120
	50	11160	9240	8390	6860	5540	4400	3420	2580	1860
D 2 11 Y	30	15710	13030	11850	9750	7950	6420	5110	3990	3040
	40	13750	11410	10370	8510	6900	5520	4350	3340	2480
	45	12760	10590	9620	7880	6370	5070	3960	3010	2200
	50	11720	9740	8860	7240	5830	4610	3560	2670	1910
C 2 12 Y	30	A RICHIESTA		ON REQUEST			SUR DEMAND		AUF ANFRAGE	
	40	A RICHIESTA		ON REQUEST			SUR DEMAND		AUF ANFRAGE	
	45	A RICHIESTA		ON REQUEST			SUR DEMAND		AUF ANFRAGE	
	50	A RICHIESTA		ON REQUEST			SUR DEMAND		AUF ANFRAGE	
C 3 12 Y	30	16310	13550	12330	10140	8270	6670	5310	4150	3180
	40	14420	11960	10870	8920	7240	5800	4570	3520	2630
	45	13450	11150	10130	8290	6710	5350	4180	3190	2350
	50	12450	10320	9360	7650	6160	4890	3790	2860	2060
D 2 13 Y	30	A RICHIESTA		ON REQUEST			SUR DEMAND		AUF ANFRAGE	
	40	A RICHIESTA		ON REQUEST			SUR DEMAND		AUF ANFRAGE	
	45	A RICHIESTA		ON REQUEST			SUR DEMAND		AUF ANFRAGE	
	50	A RICHIESTA		ON REQUEST			SUR DEMAND		AUF ANFRAGE	
D 3 13 Y	30	17810	14810	13480	11110	9070	7330	5840	4570	3490
	40	15680	13040	11860	9750	7920	6350	5010	3860	2880
	45	14600	12140	11030	9050	7330	5850	4580	3490	2560
	50	13510	11210	10190	8340	6730	5340	4140	3120	2240
D 2 15 Y	30	A RICHIESTA		ON REQUEST			SUR DEMAND		AUF ANFRAGE	
	40	A RICHIESTA		ON REQUEST			SUR DEMAND		AUF ANFRAGE	
	45	A RICHIESTA		ON REQUEST			SUR DEMAND		AUF ANFRAGE	
	50	A RICHIESTA		ON REQUEST			SUR DEMAND		AUF ANFRAGE	

Con raffreddamento della testata
With head cooling
Avec refroidissement de la tête
Mit Zylinderkopfkühlung

Capacità frigorifere

Refrigerating capacity

Puissances frigorifiques

Kälteleistungsdaten

Compressore Compressor Compresseur Verdichter	Condensazione Condensing Condensation Verflüssigungs- temperatur °C	R407C									
		Capacità frigorifera W			Refrigerating capacity W			Puissances frigorifiques W		Kälteleistungsdaten W	
		Temperatura di evaporazione °C			Evaporating temperature °C			Température d'évaporation °C		Verdampfungstemperatur °C	
		12.5	7.5	5	0	-5	-10	-15	-20	-25	
D 3 15 Y	30	20510	17030	15480	12720	10370	8360	6650	5190	3950	
	40	17970	14900	13540	11110	9010	7200	5660	4340	3220	
	45	16680	13830	12560	10280	8310	6620	5160	3910	2860	
	50	15370	12740	11560	9440	7610	6020	4650	3480	2480	
D 3 16 Y	30	A RICHIESTA			ON REQUEST			SUR DEMAND		AUF ANFRAGE	
	40	A RICHIESTA			ON REQUEST			SUR DEMAND		AUF ANFRAGE	
	45	A RICHIESTA			ON REQUEST			SUR DEMAND		AUF ANFRAGE	
	50	A RICHIESTA			ON REQUEST			SUR DEMAND		AUF ANFRAGE	
D 4 16 Y	30	22110	18340	16680	13710	11180	9010	7160	5580	4250	
	40	19400	16090	14620	11980	9720	7770	6100	4680	3470	
	45	18010	14940	13570	11110	8970	7140	5570	4220	3070	
	50	16600	13760	12500	10210	8210	6500	5020	3750	2670	
F 4 16 Y	30	23000	19080	17340	14250	11600	9340	7410	5780	4390	
	40	20270	16790	15250	12480	10100	8070	6330	4850	3590	
	45	18870	15620	14170	11580	9340	7420	5770	4370	3180	
	50	17450	14430	13080	10650	8560	6750	5210	3890	2770	
D 3 18 Y	30	A RICHIESTA			ON REQUEST			SUR DEMAND		AUF ANFRAGE	
	40	A RICHIESTA			ON REQUEST			SUR DEMAND		AUF ANFRAGE	
	45	A RICHIESTA			ON REQUEST			SUR DEMAND		AUF ANFRAGE	
	50	A RICHIESTA			ON REQUEST			SUR DEMAND		AUF ANFRAGE	
D 4 18 Y	30	24520	20360	18530	15270	12480	10100	8070	6350	4890	
	40	21560	17910	16290	13400	10910	8780	6960	5400	4080	
	45	20030	16650	15140	12440	10110	8100	6380	4910	3660	
	50	18490	15360	13970	11460	9290	7410	5800	4420	3240	
D 3 19 Y	30	A RICHIESTA			ON REQUEST			SUR DEMAND		AUF ANFRAGE	
	40	A RICHIESTA			ON REQUEST			SUR DEMAND		AUF ANFRAGE	
	45	A RICHIESTA			ON REQUEST			SUR DEMAND		AUF ANFRAGE	
	50	A RICHIESTA			ON REQUEST			SUR DEMAND		AUF ANFRAGE	
F 4 19 Y	30	26720	22180	20170	16570	13500	10880	8640	6750	5150	
	40	23530	19500	17710	14510	11760	9400	7390	5680	4220	
	45	21920	18130	16450	13450	10870	8650	6750	5130	3750	
	50	20240	16750	15190	12380	9960	7880	6100	4570	3280	
F 5 19 Y	30	26830	22260	20240	16630	13540	10900	8660	6750	5150	
	40	23720	19650	17850	14620	11830	9450	7420	5690	4230	
	45	22090	18290	16600	13560	10960	8700	6780	5140	3760	
	50	20420	16890	15310	12480	10040	7930	6130	4590	3280	
F 4 24 Y	30	A RICHIESTA			ON REQUEST			SUR DEMAND		AUF ANFRAGE	
	40	A RICHIESTA			ON REQUEST			SUR DEMAND		AUF ANFRAGE	
	45	A RICHIESTA			ON REQUEST			SUR DEMAND		AUF ANFRAGE	
	50	A RICHIESTA			ON REQUEST			SUR DEMAND		AUF ANFRAGE	
F 5 24 Y	30	32480	26980	24510	20150	16420	13240	10520	8230	6280	
	40	28560	23670	21500	17630	14310	11470	9030	6950	5190	
	45	26560	22010	19980	16360	13320	10550	8260	6290	4630	
	50	24470	20270	18400	15040	12130	9620	7470	5630	4060	
Q 4 25 Y	30	A RICHIESTA			ON REQUEST			SUR DEMAND		AUF ANFRAGE	
	40	A RICHIESTA			ON REQUEST			SUR DEMAND		AUF ANFRAGE	
	45	A RICHIESTA			ON REQUEST			SUR DEMAND		AUF ANFRAGE	
	50	A RICHIESTA			ON REQUEST			SUR DEMAND		AUF ANFRAGE	
F 5 25 Y	30	A RICHIESTA			ON REQUEST			SUR DEMAND		AUF ANFRAGE	
	40	A RICHIESTA			ON REQUEST			SUR DEMAND		AUF ANFRAGE	
	45	A RICHIESTA			ON REQUEST			SUR DEMAND		AUF ANFRAGE	
	50	A RICHIESTA			ON REQUEST			SUR DEMAND		AUF ANFRAGE	
Q 5 25 Y	30	A RICHIESTA			ON REQUEST			SUR DEMAND		AUF ANFRAGE	
	40	A RICHIESTA			ON REQUEST			SUR DEMAND		AUF ANFRAGE	
	45	A RICHIESTA			ON REQUEST			SUR DEMAND		AUF ANFRAGE	
	50	A RICHIESTA			ON REQUEST			SUR DEMAND		AUF ANFRAGE	
Q 7 25 Y	30	33930	28220	25690	21150	17270	13940	11120	8720	6700	
	40	30340	25180	22880	18770	15240	12220	9650	7470	5630	
	45	28450	23580	21410	17530	14180	11330	8890	6820	5080	
	50	26510	21940	19900	16240	13100	10410	8110	6160	4520	
Q 5 28 Y	30	A RICHIESTA			ON REQUEST			SUR DEMAND		AUF ANFRAGE	
	40	A RICHIESTA			ON REQUEST			SUR DEMAND		AUF ANFRAGE	
	45	A RICHIESTA			ON REQUEST			SUR DEMAND		AUF ANFRAGE	
	50	A RICHIESTA			ON REQUEST			SUR DEMAND		AUF ANFRAGE	
Q 7 28 Y	30	38380	31880	29040	23910	19510	15740	12520	9790	7470	
	40	33940	28180	25610	21020	17060	13660	10750	8270	6160	
	45	31660	26260	23850	19530	15780	12580	9830	7480	5490	
	50	29340	24310	22060	18010	14520	11490	8900	6690	4810	
Q 5 33 Y	30	A RICHIESTA			ON REQUEST			SUR DEMAND		AUF ANFRAGE	
	40	A RICHIESTA			ON REQUEST			SUR DEMAND		AUF ANFRAGE	
	45	A RICHIESTA			ON REQUEST			SUR DEMAND		AUF ANFRAGE	
	50	A RICHIESTA			ON REQUEST			SUR DEMAND		AUF ANFRAGE	

Con raffreddamento della testata
With head cooling
Avec refroidissement de la tête
Mit Zylinderkopfkühlung

Capacità frigorifere

Refrigerating capacity

Puissances frigorifiques

Kälteleistungsdaten

Compressore Compressor Compresseur Verdichter	Condensazione Condensing Condensation Verflüssigungs- temperatur °C	R407C									
		Capacità frigorifera W		Refrigerating capacity W			Puissances frigorifiques W			Kälteleistungsdaten W	
		Temperatura di evaporazione °C		Evaporating temperature °C			Température d'évaporation °C			Verdampfungstemperatur °C	
		12.5	7.5	5	0	-5	-10	-15	-20	-25	
S 5 33 Y	30	A RICHIESTA		ON REQUEST			SUR DEMAND			AUF ANFRAGE	
	40										
	45										
	50										
Q 7 33 Y	30	44970	37330	33970	28000	22880	18500	14770	11610	8930	
	40	39720	32980	29990	24640	20050	16120	12750	9890	7460	
	45	37050	30750	27940	22920	18600	14880	11700	9000	6700	
	50	34350	28490	25850	21160	17110	13630	10650	8100	5940	
S 7 33 Y	30	46730	38730	35200	28900	23520	18930	15030	11710	8910	
	40	41080	34010	30870	25270	20460	16340	12830	9830	7290	
	45	38170	31580	28650	23410	18890	15010	11700	8860	6460	
	50	35270	29150	26420	21500	17290	13660	10560	7890	5630	
S 7 39 Y	30	A RICHIESTA		ON REQUEST			SUR DEMAND			AUF ANFRAGE	
	40										
	45										
	50										
S 10 39 Y	30	55040	45640	41490	34130	27760	22320	17790	13890	10580	
	40	48390	40100	36420	29850	24190	19350	15210	11680	8690	
	45	45050	37310	33860	27670	22360	17790	13890	10550	7720	
	50	41600	34420	31220	25470	20480	16210	12540	9410	6740	
S 10 51 Y	30	A RICHIESTA		ON REQUEST			SUR DEMAND			AUF ANFRAGE	
	40										
	45										
	50										
S 15 51 Y	30	69610	57700	52460	43140	35190	28400	22610	17680	13500	
	40	61090	50640	46010	37720	30610	24510	19320	14880	11100	
	45	56890	47120	42740	34970	28280	22540	17630	13440	9870	
	50	52560	43520	39470	32180	25920	20540	15920	11990	8630	
S 15 56 Y	30	A RICHIESTA		ON REQUEST			SUR DEMAND			AUF ANFRAGE	
	40										
	45										
	50										
S 20 56 Y	30	78460	65230	59380	48950	40020	32400	25910	20390	15740	
	40	69410	57690	52480	43210	35180	28310	22450	17460	13230	
	45	64730	53790	48920	40190	32700	26210	20670	15950	11950	
	50	60030	49800	45280	37140	30110	24040	18850	14410	10640	
V 15 59 Y	30	A RICHIESTA		ON REQUEST			SUR DEMAND			AUF ANFRAGE	
	40										
	45										
	50										
V 20 59 Y	30	82580	68570	62380	51320	41850	33760	26850	20980	16020	
	40	72760	60390	54900	45030	36560	29270	23030	17710	13200	
	45	67740	56200	51060	41820	33840	26960	21070	16030	11760	
	50	62710	51920	47140	38520	31060	24610	19060	14320	10300	
V 15 71 Y	30	A RICHIESTA		ON REQUEST			SUR DEMAND			AUF ANFRAGE	
	40										
	45										
	50										
V 25 71 Y	30	97450	80870	73550	60580	49400	39850	31710	24800	18960	
	40	86080	71420	64910	53250	43240	34610	27250	20980	15680	
	45	80220	66550	60440	49480	40030	31910	24950	19020	13990	
	50	74300	61520	55850	45630	36770	29150	22610	17020	12280	
V 20 84 Y	30	A RICHIESTA		ON REQUEST			SUR DEMAND			AUF ANFRAGE	
	40										
	45										
	50										
V 30 84 Y	30	115770	96190	87520	72060	58810	47490	37830	29630	22690	
	40	102190	84890	77200	63370	51500	41290	32560	25120	18820	
	45	95170	79040	71850	58930	47740	38100	29840	22800	16830	
	50	88140	73070	66380	54340	43890	34840	27080	20450	14820	
V 25 93 Y	30	A RICHIESTA		ON REQUEST			SUR DEMAND			AUF ANFRAGE	
	40										
	45										
	50										
V 32 93 Y	30	129990	108040	98350	81080	66260	53590	42780	33580	25800	
	40	114350	95110	86480	71210	58020	46660	36900	28570	21510	
	45	106400	88510	80540	66140	53770	43120	33870	25990	19300	
	50	98270	81790	74390	61050	49430	39430	30780	23370	17060	
V 25 103 Y	30	A RICHIESTA		ON REQUEST			SUR DEMAND			AUF ANFRAGE	
	40										
	45										
	50										

Con raffreddamento della testata
With head cooling
Avec refroidissement de la tête
Mit Zylinderkopfkühlung

Capacità frigorifere

Refrigerating capacity

Puissances frigorifiques

Kälteleistungsdaten

Compressore Compressor Compresseur Verdichter	Condensazione Condensing Condensation Verflüssigungs- temperatur °C	R407C									
		Capacità frigorifera W			Refrigerating capacity W			Puissances frigorifiques W		Kälteleistungsdaten W	
		Temperatura di evaporazione °C			Evaporating temperature °C			Température d'évaporation °C		Verdampfungstemperatur °C	
		12.5	7.5	5	0	-5	-10	-15	-20	-25	
V 35 103 Y	30	143970	119690	108900	89610	73060	58920	46900	36710	28120	
	40	128590	106630	96870	79380	64350	51510	40580	31300	23480	
	45	120540	99810	90580	74040	59820	47660	37300	28500	21090	
	50	112220	92760	84090	68540	55160	43710	33950	25660	18660	
Z 25 106 Y	30	A RICHIESTA			ON REQUEST			SUR DEMAND		AUF ANFRAGE	
	40	A RICHIESTA			ON REQUEST			SUR DEMAND		AUF ANFRAGE	
	45	A RICHIESTA			ON REQUEST			SUR DEMAND		AUF ANFRAGE	
	50	A RICHIESTA			ON REQUEST			SUR DEMAND		AUF ANFRAGE	
Z 35 106 Y	30	145970	121300	110340	90730	73910	59550	47330	36970	28240	
	40	130270	107960	98040	80260	65000	51940	40830	31400	23460	
	45	122050	100990	91610	74800	60350	47990	37460	28530	20990	
	50	113570	93800	84990	69180	55590	43950	34030	25600	18490	
Z 30 126 Y	30	A RICHIESTA			ON REQUEST			SUR DEMAND		AUF ANFRAGE	
	40	A RICHIESTA			ON REQUEST			SUR DEMAND		AUF ANFRAGE	
	45	A RICHIESTA			ON REQUEST			SUR DEMAND		AUF ANFRAGE	
	50	A RICHIESTA			ON REQUEST			SUR DEMAND		AUF ANFRAGE	
Z 40 126 Y	30	172380	143150	130250	107250	87570	70750	56400	44230	33840	
	40	151690	125990	114570	94110	76460	61270	48330	37280	27900	
	45	141070	117140	106480	87330	70750	56410	44190	33740	24860	
	50	130310	108150	98240	80400	64920	51530	39990	30160	21790	
W 40 142 Y	30	194950	162130	147620	121730	99550	80590	64410	50650	39000	
	40	172320	143310	130410	107310	87410	70330	55720	43250	32680	
	45			121590	99890	81180	65050	51240	39440	29430	
	50			92300	74760	59650	46670	35560	26130		
Z 40 154 Y	30	A RICHIESTA			ON REQUEST			SUR DEMAND		AUF ANFRAGE	
	40	A RICHIESTA			ON REQUEST			SUR DEMAND		AUF ANFRAGE	
	45	A RICHIESTA			ON REQUEST			SUR DEMAND		AUF ANFRAGE	
	50	A RICHIESTA			ON REQUEST			SUR DEMAND		AUF ANFRAGE	
Z 50 154 Y	30	207150	172360	156990	129580	105990	85950	68820	54230	41850	
	40	182310	151850	138300	114010	92990	74860	59410	46210	34990	
	45	169730	141390	128750	106000	86280	69250	54580	42090	31470	
	50	157010	130750	119010	97820	79410	63450	49660	37910	27900	
W 40 168 Y	30	A RICHIESTA			ON REQUEST			SUR DEMAND		AUF ANFRAGE	
	40	A RICHIESTA			ON REQUEST			SUR DEMAND		AUF ANFRAGE	
	45	A RICHIESTA			ON REQUEST			SUR DEMAND		AUF ANFRAGE	
	50	A RICHIESTA			ON REQUEST			SUR DEMAND		AUF ANFRAGE	
W 50 168 Y	30	231010	192120	174920	144230	117930	95460	76290	59980	46190	
	40	204110	169770	154510	127150	103580	83330	66000	51220	38700	
	45		158300	144010	118350	96140	77070	60700	46710	34850	
	50			133280	109340	88590	70680	55280	42120	30950	
W 50 187 Y	30	A RICHIESTA			ON REQUEST			SUR DEMAND		AUF ANFRAGE	
	40	A RICHIESTA			ON REQUEST			SUR DEMAND		AUF ANFRAGE	
	45	A RICHIESTA			ON REQUEST			SUR DEMAND		AUF ANFRAGE	
	50	A RICHIESTA			ON REQUEST			SUR DEMAND		AUF ANFRAGE	
W 60 187 Y	30	257510	214140	194940	160680	131330	106250	84880	66710	51360	
	40	227920	189510	172430	141810	115410	92790	73450	56980	43040	
	45	212530	176710	160740	132010	107200	85840	67550	51970	38750	
	50	196990	163580	148740	122000	98800	78730	61540	46860	34410	
W 60 206 Y	30	A RICHIESTA			ON REQUEST			SUR DEMAND		AUF ANFRAGE	
	40	A RICHIESTA			ON REQUEST			SUR DEMAND		AUF ANFRAGE	
	45	A RICHIESTA			ON REQUEST			SUR DEMAND		AUF ANFRAGE	
	50	A RICHIESTA			ON REQUEST			SUR DEMAND		AUF ANFRAGE	
W 70 206 Y	30	285610	237530	216260	178280	145720	117870	94130	73960	56920	
	40	252710	210250	191280	157320	128080	102980	81500	63200	47710	
	45	236320	196390	178310	145900	118050	94220	73920	56690	42160	
	50	219340	182030	165380	135450	109620	87390	68310	52000	38170	
W 70 228 Y	30	A RICHIESTA			ON REQUEST			SUR DEMAND		AUF ANFRAGE	
	40	A RICHIESTA			ON REQUEST			SUR DEMAND		AUF ANFRAGE	
	45	A RICHIESTA			ON REQUEST			SUR DEMAND		AUF ANFRAGE	
	50	A RICHIESTA			ON REQUEST			SUR DEMAND		AUF ANFRAGE	
W 75 228 Y	30	316500	263190	239600	197470	161320	130440	100150			
	40	280220	232960	211940	174280	141850	114020	90180			
	45	261370	217430	197630	162290	131760	105500	82970			
	50	242020	201190	182920	149990	121410	96770	75610			
W 75 240 Y	30	A RICHIESTA			ON REQUEST			SUR DEMAND		AUF ANFRAGE	
	40	A RICHIESTA			ON REQUEST			SUR DEMAND		AUF ANFRAGE	
	45	A RICHIESTA			ON REQUEST			SUR DEMAND		AUF ANFRAGE	
	50	A RICHIESTA			ON REQUEST			SUR DEMAND		AUF ANFRAGE	
W 80 240 Y	30	331660	275790	251070	206950	196140	136770	109200			
	40	293270	243880	221930	182550	148630	119510	94550			
	45	273350	227340	206820	169940	138020	110550	86990			
	50	253240	210380	191330	157070	127160	101390	79260			

Con raffreddamento della testata
With head cooling
Avec refroidissement de la tête
Mit Zylinderkopfkühlung

Capacità frigorifere

Refrigerating capacity

Puissances frigorifiques

Kälteleistungsdaten

Compressore Compressor Compresseur Verdichter	Condensazione Condensing Condensation Verflüssigungs- temperatur °C	R22														
		Capacità frigorifera W				Refrigerating capacity W				Puissances frigorifiques W				Kälteleistungsdaten W		
		Temperatura di evaporazione °C				Evaporating temperature °C				Température d'évaporation °C				Verdampfungstemperatur °C		
		12.5	7.5	5	0	-5	-10	-15	-20	-25	-30	-35	-40	-45		
A 0.5 4 Y	30	5100	4250	3870	3190	2600	2110	1670	1300	990	740	530	370			
	40	4520	3750	3410	2800	2280	1840	1440	1110	830	610	430	290			
	45	4230	3510	3190	2620	2120	1700	1330	1020	760	550	380	250			
	50	3940	3260	2960	2430	1960	1570	1220	920	680	190	330	210			
A 0.5 5 Y	30					3260	2650	2110	1650	1270	950	700	490			
	40					2860	2310	1830	1420	1090	800	570	390			
	45					2660	2150	1690	1310	990	720	510	340			
	50					2460	1980	1550	1190	890	650	450	290			
A 0.7 5 Y	30	6360	5290	4820	3980	3260	2650	2110	1650	1270	950	700	490			
	40	5610	4670	4250	3500	2860	2310	1830	1420	1080	800	570	390			
	45	5240	4360	3970	3270	2670	2150	1690	1310	990	720	510	340			
	50	4860	4050	3680	3030	2470	1980	1560	1200	890	650	450	290			
A 0.7 6 Y	30					3590	2920	2330	1830	1410	1060	780	550	370		
	40					3150	2550	2020	1570	1200	890	630	430	280		
	45					2930	2370	1870	1450	1090	800	570	380	240		
	50					2710	2180	1720	1320	990	720	500	330			
A 1 6 Y	30	7090	5910	5380	4450	3650	2960	2350	1840	1420	1070	780	550			
	40	6280	5230	4760	3930	3210	2590	2050	1590	1210	890	640	440			
	45	5890	4900	4460	3670	2990	2410	1900	1470	1110	810	570	380			
	50	5480	4560	4150	3410	2780	2230	1750	1340	1010	730	500	330			
A 1 7 Y	30					4650	300	3050	2420	1890	1440	1080	780	550		
	40					4110	3350	2690	2120	1640	1240	920	650	440		
	45					3850	3130	2510	1970	1520	1150	840	590	390		
	50					3570	2910	2320	1830	1400	1050	760	520			
A 1.5 7 Y	30	9060	7580	6920	5740	4730	3860	3100	2450	1910	1460	1090				
	40	8110	6780	6190	5120	4210	3420	2730	2150	1670	1260	920				
	45	7630	6380	5820	4820	3950	3210	2560	2010	1540	1160	840				
	50	7160	5980	5450	4510	3690	2990	2380	1860	1420	1060	760				
A 1.5 8 Y	30	10350	8620	7860	6490	5320	4350	3510	2800	2180	1670	1240	890			
	40	9230	7690	7000	5770	4720	2850	3090	2450	1890	1430	1040	720			
	45	8690	7230	6580	5420	4410	3600	2880	2270	1750	1310	940	640			
	50	8120	6760	6150	5060	4110	3340	2670	2090	1600	1180	840	560			
B 1.5 9 Y	30					9220	7630	6280	5130	4170	3340	2640	2040	1540	1130	790
	40					8190	6780	5570	4530	3660	2910	2270	1740	1290	920	610
	45					7690	6360	5220	4230	3410	2700	2100	1590	1160	810	530
	50					7170	5930	4860	3930	3160	2490	1920	1440	1040	720	
B 1.5 10 Y	30					7060	5780	4680	3750	2950	2290	1730	1270	900		
	40					6260	5110	4120	3280	2560	1960	1460	1050	720		
	45					5870	4780	3850	3050	2370	1800	1330	940	630		
	50					5470	4450	3570	2820	2180	1640	1200	830			
B 2 10 Y	30	13620	11380	10390	8610	7090	5780	4670	3710	2900	2210					
	40	12150	10140	9240	7640	6270	5090	4070	3210	2480	1860					
	45	11420	9520	8680	7160	5860	4750	3780	2970	2270	1690					
	50	10660	8890	8100	6680	5450	4400	3500	2720	2070	1520					
C 2 11 Y	30	14900	12520	11450	9540	7890	6470	5240	4180	3280	2510	1860				
	40	13400	11250	10290	8550	7050	5750	4620	3650	2810	2100	1500				
	45	12650	10620	9700	8060	6630	5380	4310	3380	2580	1890					
	50	11890	9970	9100	7550	6190	5010	3990	3100	2340						
D 2 11 Y	30	15380	12800	11670	9710	8020	6570	5320	4250	3310	2520	1850				
	40	13610	11350	10350	8620	7110	5810	4670	3700	2840	2110	1510				
	45	12780	10660	9710	8080	6660	5430	4350	3420	2600	1910	1330				
	50	11940	9960	9070	7540	6210	5040	4020	3140	2360	1710	1160				
C 2 12 Y	30					8690	7130	5770	4610	3610	2760	2050	1440	940		
	40					7770	6330	5090	4020	3100	2320	1650	1090	620		
	45					7300	5930	4750	3720	2840	2090	1450	910			
	50					6820	5520	4390	3420	2570	1850	1240				
C 3 12 Y	30	16540	13900	12720	10590	8760	7180	5810	4640	3630	2780					
	40	14930	12530	11460	9520	7840	6390	5130	4050	3120	2330					
	45	14120	11840	10820	8980	7380	5990	4790	3750	2860	2100					
	50	13270	11130	10160	8410	6900	5580	4430	3440	2590	1860					
D 2 13 Y	30					13870	11570	9590	7880	6400	5120	4040	3110	2330	1660	1110
	40					12270	10240	8480	6950	5620	4460	3470	2630	1910	1310	810
	45					11500	9590	7940	6490	5230	4130	3180	2380	1700	1130	660
	50					10680	8920	7380	6020	4830	3800	2900	2140	1490	960	
D 3 13 Y	30	18370	15340	14000	11630	9590	7840	6330	5040	3930	2990					
	40	16320	13640	12450	10320	8480	6900	5540	4360	3350	2500					
	45	15350	12820	11680	9680	7940	6440	5140	4020	3060	2250					
	50	14350	11970	10910	9030	7390	5970	4740	3680	2770	2010					
D 2 15 Y	30					10640	8730	7080	5670	4470	3450	2590	1860	1270		
	40					9400	7700	6220	4940	3940	2910	2130	1470	930		
	45					8780	7190	5790	4570	3530	2650	1900	1280	770		
	50					8150	6660	5350	4210	3220	2380	1680	1090			

Con raffreddamento della testata
With head cooling
Avec refroidissement de la tête
Mit Zylinderkopfkühlung

Capacità frigorifere

Refrigerating capacity

Puissances frigorifiques

Kälteleistungsdaten

Compressore Compressor Compresseur Verdichter	Condensazione Condensing Condensation Verflüssigungs- temperatur °C	R134a							
		Capacità frigorifera W *		Refrigerating capacity W *		Puissances frigorifiques W *		Kälteleistungsdaten W *	
		Temperatura di evaporazione °C		Evaporating temperature °C		Température d'évaporation °C		Verdampfungstemperatur °C	
		12.5	7.5	5	0	-5	-10	-15	-20
A 0.5 4 Y	30	3400	2820	2560	2100	1700	1370	1080	840
	40	3030	2510	2280	1860	1500	1190	930	710
	45	2850	2360	2140	1740	1400	1110	860	650
	50	2660	2200	1990	1620	1290	1020	780	580
A 0.5 5 Y	30	4280	3560	3230	2650	2150	1730	1370	1060
	40	3800	3160	2870	2350	1900	1510	1190	910
	45	3570	2960	2690	2200	1770	1400	1090	830
	50	3340	2760	2510	2040	1640	1290	1000	740
A 0.7 5 Y	50	3340	2770	2510	2040	1640	1290	1000	740
	60	2860	2370	2140	1730	1380	1070	810	580
	70	2380	1960	1770	1420	1110	850	620	420
	80	1890	1550	1390	1100	850	630	440	270
A 0.7 6 Y	30	4760	3920	3560	2930	2380	1910	1510	1180
	40	4190	3480	3160	2590	2100	1670	1310	1000
	45	3930	3260	2960	2420	1960	1550	1210	910
	50	3660	3040	2760	2250	1810	1430	1100	820
A 1 6 Y	50	3730	3090	2800	2280	1830	1440	1110	830
	60	3210	2650	2390	1930	1540	1190	900	650
	70	2670	2190	1980	1580	1240	940	690	470
	80	2120	1730	1560	1230	950	700	480	300
A 1 7 Y	30	6140	5090	4630	3800	3090	2490	1970	1530
	40	5440	4520	4110	3360	2730	2170	1700	1300
	45	5100	4230	3850	3140	2540	2010	1570	1180
	50	4760	3950	3580	2920	2350	1850	1430	1070
A 1.5 7 Y	50	4880	4030	3650	2970	2380	1880	1440	1070
	60	4190	3450	3120	2520	2000	1550	1170	840
	70	3490	2860	2580	2060	1610	1220	890	610
	80	2780	2260	2030	1600	1230	900	630	390
A 1.5 8 Y	30	6850	5690	5170	4240	3450	2770	2190	1690
	40	6100	5060	4590	3760	3040	2420	1890	1440
	45	5730	4740	4300	3510	2830	2240	1740	1310
	50	5350	4430	4010	3260	2620	2060	1580	1180
B 1.5 9 Y	30	8080	6700	6090	4990	4050	3250	2560	1980
	40	7170	5940	5400	4410	3560	2830	2200	1670
	45	6730	5570	5050	4110	3310	2610	2020	1510
	50	6280	5190	4700	3820	3060	2400	1830	1350
B 1.5 10 Y	30	9110	7560	6870	5640	4580	3680	2910	2250
	40	8090	6700	6090	4980	4030	3210	2510	1910
	45	7580	6280	5700	4650	3750	2970	2300	1730
	50	7070	5860	5310	4320	3470	2730	2100	1560
B 2 10 Y	50	6920	5720	5180	4210	3370	2640	2010	1480
	60	5930	4880	4400	3550	2800	2160	1610	1130
	70	4920	4060	3620	2880	2240	1680	1200	790
	80	3890	3160	2830	2220	1680	1220	810	470
C 2 11 Y	50	7850	6480	5860	4750	3790	2970	2270	1670
	60	6730	5530	4990	4010	3160	2430	1810	1270
	70	5590	4560	4100	3260	2530	1890	1350	890
	80	4420	3580	3200	2510	1900	1370	920	
D 2 11 Y	50	7840	6470	5860	4760	3800	2970	2260	1650
	60	6690	5500	4960	3990	3150	2420	1780	1230
	70	5540	4520	4060	3230	2500	1860	1310	830
	80	4360	3530	3150	2460	1850	1320	860	450
C 2 12 Y	30	10780	8900	8070	6580	5310	4230	3310	2530
	40	9370	7730	7000	5690	4570	3610	2800	2100
	45	8760	7220	6530	5300	4240	3330	2550	1890
	50	7990	6600	5980	4850	3890	3060	2350	1750
C 3 12 Y	50	8170	6730	6090	4940	3950	3110	2390	1790
	60	6940	5720	5160	4170	3320	2590	1970	1440
	70	5750	4730	4270	3440	2710	2090	1550	1100
	80	4570	3760	3390	2710	2120	1600	1160	
D 2 13 Y	30	11970	9930	9030	7410	6010	4820	3800	2920
	40	10600	8780	7960	6510	5250	4170	3240	2450
	45	9920	8210	7440	6060	4880	3850	2960	2210
	50	9250	7640	6920	5610	4490	3520	2680	1960
D 3 13 Y	50	9410	7740	7000	5660	4500	3500	2650	1930
	60	8030	6580	5920	4740	3720	2840	2080	1430
	70	6630	5390	4830	3820	2940	2170	1520	950
	80	5220	4200	3740	2900	2170	1530	980	510
D 2 15 Y	30	13810	11480	10430	8570	6980	5590	4410	3390
	40	12250	10160	9230	7540	6090	4840	3760	2830
	45	11470	9500	8620	7020	5650	4460	3430	2550
	50	10690	8840	8010	6500	5200	4070	3100	2260

* tabella con capacità frigorifere a -25°C e -30°C disponibili a richiesta
 refrigerating capacities at -25°C and -30°C available upon request
 puissances frigorifiques a -25°C et -30°C disponibles sur demande
 Kälteleistungsdaten bei -25°C und -30°C sind auf Wunsch verfügbar

Con raffreddamento della testata
 With head cooling
 Avec refroidissement de la tête
 Mit Zylinderkopfkühlung

Capacità frigorifere

Refrigerating capacity

Puissances frigorifiques

Kälteleistungsdaten

Compressore Compressor Compresseur Verdichter	Condensazione Condensing Condensation Verflüssigungs- temperatur °C	R134a							
		Capacità frigorifera W *		Refrigerating capacity W *		Puissances frigorifiques W *		Kälteleistungsdaten W *	
		Temperatura di evaporazione °C		Evaporating temperature °C		Température d'évaporation °C		Verdampfungstemperatur °C	
		12.5	7.5	5	0	-5	-10	-15	-20
D 3 15 Y	50	10720	8830	7990	6460	5140	4010	3030	2200
	60	9140	7500	6750	5410	4240	3240	2370	1630
	70	7550	6140	5510	4350	3350	2470	1720	1080
	80	5930	4790	4260	3300	2470	1740	1100	560
D 3 16 Y	30	14520	12020	10910	8920	7230	5770	4540	3480
	40	12840	10620	9630	7840	6310	4990	3860	900
	45	12020	9920	8980	7300	5850	4590	3520	2610
	50	11190	9230	8340	6750	5380	4190	3180	2310
D 4 16 Y	50	11450	9420	8150	6880	5470	4250	3210	2330
	60	9770	7990	7200	5760	4520	3440	2520	1730
	70	8060	6560	5870	4640	3570	2630	1840	1150
	80	6340	5110	4550	3530	2630	1850	1180	610
F 4 16 Y	50	11980	9880	8940	7240	5780	4530	3460	2550
	60	10270	8430	7600	6110	4820	3710	2770	1960
	70	8530	6960	6250	4970	3860	2900	2080	1370
	80	6760	5480	4890	3830	2910	2100	1410	820
D 3 18 Y	30	17020	14100	12810	10490	8510	6810	5360	4130
	40	15070	12480	11310	9240	7440	5900	4580	3460
	45	14100	11670	10580	8600	6900	5440	4180	3110
	50	13130	10850	9820	7960	6360	4970	3780	2770
D 4 18 Y	50	13420	11060	10000	8090	6450	5030	3820	2790
	60	11440	9380	8460	6790	5340	4090	3020	2100
	70	9450	7700	6910	5480	4230	3150	2220	1420
	80	7430	6010	5360	4180	3150	2240	1460	790
D 3 19 Y	30	18630	15440	14030	11500	9330	7480	5900	4560
	40	16480	13660	12390	10120	8170	6490	5050	3830
	45	15410	12760	11570	9440	7580	5990	4620	3460
	50	14340	11860	10750	8740	6990	5480	4190	3080
F 4 19 Y	50	13910	11540	10480	8570	6930	5520	4320	3290
	60	12010	9940	9010	7340	5900	4650	3590	2680
	70	10070	8320	7520	6090	4850	3780	2850	2060
	80	8080	6650	6000	4830	3790	2900	2130	1470
F 5 19 Y	50	13890	11490	1042	8500	6860	5440	4240	3220
	60	12010	9910	8970	7280	5820	4570	3510	2600
	70	10060	8290	7480	6030	4770	3690	2770	1980
	80	806	6610	5960	4760	3720	2820	2050	1380
F 4 24 Y	30	21410	17750	16130	13260	10800	8700	6920	5400
	40	19050	15810	14360	11780	9550	7650	6030	4650
	45	17880	14830	13470	11030	8920	7120	5580	4270
	50	16720	13850	12570	10270	8290	6580	5130	3880
F 5 24 Y	50	16570	13690	12390	10090	8100	6390	4950	3710
	60	14220	11730	10600	8580	6820	5320	4030	2940
	70	11850	9730	8770	7050	5540	4240	3130	2180
	80	9420	7700	6920	5500	4260	3180	2240	1450
Q 4 25 Y	30	22630	18750	17040	13950	11310	9040	7120	5480
	40	20080	16620	15070	12290	9900	7840	6090	4590
	45	18810	15550	14090	11460	9180	7230	5560	4130
	50	17550	14470	13090	10610	8460	6610	5030	3680
F 5 25 Y	30	23560	19550	17770	14600	11890	9580	7620	5960
	40	21070	17470	15870	13000	10550	8450	6670	5150
	45	19800	16420	14910	12190	9870	7880	6180	4740
	50	18510	15340	13920	11380	9180	7300	5690	4330
Q 5 25 Y	30	23040	19120	17370	14270	11630	9370	7460	5840
	40	20510	17020	15460	12680	10300	8260	6520	5050
	45	19230	15950	14490	11870	9620	7690	6050	4640
	50	17970	14900	13520	11060	8940	7130	5570	4240
Q 7 25 Y	50	17970	14900	13520	11060	8940	7130	5570	4240
	60	15430	12770	11580	9440	7580	5980	4600	3430
	70	12860	10630	9620	7790	6200	4830	3640	2620
	80	10260	8460	7630	6140	4830	3690	2700	1850
Q 5 28 Y	30	26000	21610	19650	16180	13200	10660	8500	6670
	40	23190	19300	17560	14440	11740	9430	7470	5790
	45	21810	18140	16500	13550	11010	8810	6940	5350
	50	20410	16960	15420	12650	10250	8180	6410	4900
Q 7 28 Y	50	20210	16620	15010	12120	9630	7490	5660	4110
	60	17270	14120	12710	10160	7960	6060	4440	3060
	70	14280	11590	10380	8190	6290	4640	3240	2030
	80	11230	9040	8040	6230	4650	3270	2090	1080
Q 5 33 Y	30	31210	25860	23490	19230	15570	12440	9780	7520
	40	27640	22880	20750	16940	13630	10780	8360	6300
	45	25860	21380	19380	15770	12660	9940	7640	5670
	50	24070	19890	17990	14600	11660	9100	6910	5040

* tabelle con capacità frigorifere a -25°C e -30°C disponibili a richiesta
 refrigerating capacities at -25°C and -30°C available upon request
 puissances frigorifiques à -25°C et -30°C disponibles sur demande
 Kälteleistungsdaten bei -25°C und -30°C sind auf Wunsch verfügbar

Capacità frigorifere

Refrigerating capacity

Puissances frigorifiques

Kälteleistungsdaten

Compressore Compressor Compresseur Verdichter	Condensazione Condensing Condensation Verflüssigung- temperatur °C	R134a							
		Capacità frigorifera W *		Refrigerating capacity W *		Puissances frigorifiques W *		Kälteleistungsdaten W *	
		Temperatura di evaporazione °C		Evaporating temperature °C		Température d'évaporation °C		Verdampfungstemperatur °C	
		12.5	7.5	5	0	-5	-10	-15	-20
S 5 33 Y	30	30540	25380	23100	19020	15540	12550	10010	7850
	40	27220	22630	20590	16930	13770	11070	8760	6790
	45	25570	21260	19330	15860	12880	10320	8130	6260
	50	23920	19870	18060	14800	11980	9560	7490	5710
Q 7 33 Y	50	24650	20280	18320	14820	11790	9200	6980	5100
	60	21040	17250	15500	12440	9770	7470	5510	3830
	70	17390	14150	12690	10050	7750	5760	4060	2600
	80	13700	11060	9850	7670	5760	4100	2670	1440
S 7 33 Y	50	23850	19730	17890	14580	11740	9310	7230	5460
	60	20500	16930	15320	12430	9930	7780	5940	4370
	70	17110	14090	12720	10250	8100	6250	4650	3290
	80	13670	11200	10090	8050	6270	4730	3390	2250
S 7 39 Y	30	35970	29870	27160	22340	18210	14700	11710	9170
	40	32080	26650	24230	19890	16170	12980	10260	7950
	45	30130	25030	22750	18660	15130	12110	9530	7330
	50	28170	23400	21260	17410	14070	11230	8780	6700
S 10 39 Y	50	27900	23110	20990	17160	13870	11040	8640	6590
	60	24070	19920	18050	14680	11800	9210	7170	5360
	70	20170	16650	15060	12190	9710	7550	5710	4130
	80	16180	13310	12010	9650	7590	5810	4270	2940
S 10 51 Y	30	46010	38180	34700	28540	23240	18720	14880	11610
	40	40970	34000	30900	25330	20550	16460	12970	9990
	45	38440	31900	28970	23720	19190	15310	11990	9160
	50	39540	29780	27030	22090	17820	14140	11010	8330
S 15 51 Y	50	35940	29750	26980	22000	17720	14040	10900	8220
	60	30850	25460	23030	18700	14950	11710	8940	6560
	70	25720	21150	19090	15370	12170	9380	6980	4920
	80	20530	16790	15110	12050	9400	7080	5080	3340
S 15 56 Y	30	51870	43070	39170	32230	26290	21210	16880	13190
	40	46090	38300	34810	28590	23250	18660	14730	11360
	45	43270	35940	32660	26770	21720	17370	13630	10440
	50	40450	33570	30490	24940	20170	16060	12530	9500
S 20 56 Y	50	41230	34130	30950	25250	20340	16130	12550	9490
	60	35520	29340	26560	21550	17230	13510	10330	7620
	70	29690	24460	22110	17810	14090	10870	8120	5760
	80	23730	19480	17540	14020	10930	8250	5950	3970
V 15 59 Y	30	55160	45800	41650	34250	27920	22490	17870	13940
	40	49000	40690	36980	30350	24660	19750	15560	11970
	45	45990	38170	34670	28410	23010	18370	14380	10970
	50	42970	35640	32350	26440	21350	16960	13190	9960
V 20 59 Y	50	44140	36430	32980	26780	21440	16860	12950	9620
	60	37870	31150	28130	22680	17970	13910	10440	7480
	70	31490	25780	23200	18530	14470	10960	7960	5380
	80	24990	20350	18220	14370	11000	8070	5550	3390
V 15 71 Y	30	65020	53990	49100	40390	32990	26650	21230	16600
	40	57800	47990	43640	35840	29140	23420	18510	14300
	45	54250	45060	40920	33560	27220	21780	17130	13130
	50	50650	42090	38230	31260	25280	20140	15740	11950
V 25 71 Y	50	50070	41370	37480	30490	24480	19330	14950	11210
	60	43090	35500	32090	25940	20630	16070	12180	8860
	70	35970	29510	26590	21320	16750	12080	9430	6550
	80	28690	23410	21010	16670	12870	9580	6760	4340
V 20 84 Y	30	75510	62740	57070	46950	38280	30870	24570	19210
	40	67190	55890	50830	41750	33930	27210	21480	16580
	45	63060	52450	47690	39160	31730	25350	19900	15250
	50	59000	49000	44530	36480	29500	23470	18310	13900
V 30 84 Y	50	59530	49260	44660	36410	29310	23220	18030	13610
	60	51320	42350	38320	31070	24800	19410	14810	10890
	70	42920	35310	31870	25640	20250	15590	11600	8190
	80	34290	28140	25290	20160	15680	11800	8460	5600
V 25 93 Y	30	83730	69510	63180	51970	42360	34140	27160	21240
	40	74640	62010	56370	46260	37570	30110	23750	18330
	45	70100	58260	52930	43370	35120	28050	22010	16860
	50	65610	54450	49470	40460	32700	25980	20250	15360
V 32 93 Y	50	66530	55190	50100	40930	33040	26250	20460	15520
	60	57340	47500	43050	35010	28040	22030	16900	12510
	70	47970	39650	35870	28980	22980	17790	13330	9520
	80	38440	31620	28530	22850	17890	13560	9830	6630
V 25 103 Y	30	91460	75900	68970	56630	46120	37130	29490	23010
	40	81380	67540	61360	50290	40820	32650	25710	19800
	45	76390	63350	57550	47090	38100	30380	23780	18160
	50	71320	59170	53680	43870	35380	28070	21840	16510

* tabella con capacità frigorifere a -25°C e -30°C disponibili a richiesta
 refrigerating capacities at -25°C and -30°C available upon request
 puissances frigorifiques a -25°C et -30°C disponibles sur demande
 Kälteleistungsdaten bei -25°C und -30°C sind auf Wunsch verfügbar

Capacità frigorifere

Refrigerating capacity

Puissances frigorifiques

Kälteleistungsdaten

Compressore Compressor Compresseur Verdichter	Condensazione Condensing Condensation Verflüssigungs- temperatur °C	R134a							
		Capacità frigorifera W *		Refrigerating capacity W *		Puissances frigorifiques W *		Kälteleistungsdaten W *	
		Temperatura di evaporazione °C		Evaporating temperature °C		Température d'évaporation °C		Verdampfungstemperatur °C	
		12.5	7.5	5	0	-5	-10	-15	-20
V 35 103 Y	50	72750	60070	54400	44240	35520	28070	21740	16370
	60	62960	51800	46800	37830	30110	23490	17870	13100
	70	52870	43310	39100	31280	24610	18880	14000	9850
	80	42420	34570	31020	24620	19070	14290	10210	6720
Z 25 106 Y	30	96730	80310	73020	60010	48900	39390	31310	24440
	40	86130	71560	65030	53340	43330	34670	27310	21040
	45	80880	67130	61010	49970	40450	32270	25280	19310
	50	75540	62740	56930	46570	37580	29850	23220	17570
Z 35 106 Y	50	76200	62920	56980	46340	37200	29400	22760	17140
	60	65940	54240	49020	39610	31530	24600	18710	13710
	70	55370	45360	40860	32760	25770	19770	14660	10310
	80	44420	36200	32490	25780	19970	14960	10680	7040
Z 30 126 Y	30	115780	96120	87390	71820	58510	47130	37460	29250
	40	103020	85610	77830	63850	51800	41480	32680	25180
	45	96610	80290	72980	59840	48410	38610	30240	23110
	50	90310	74940	68090	55720	44980	35710	27790	21020
Z 40 126 Y	50	89250	73800	66880	54460	43760	34570	26710	19980
	60	76630	63090	57040	46150	36730	28620	21650	15680
	70	63730	52330	47160	37780	29680	22670	16630	11440
	80	50620	41360	37130	29400	22680	16830	11780	7420
W 40 142 Y	50	100040	82730	74980	61080	49120	38860	30110	22670
	60	86020	70990	64210	52010	41470	32400	24650	18040
	70	71870	59060	53270	42830	33760	25930	19220	13480
	80	57340	46910	42210	33560	26050	19530	13920	9100
Z 40 154 Y	30	141500	117400	106720	87720	71500	57710	45890	35870
	40	125830	104450	94820	77790	63170	50640	39960	30850
	45	118060	97980	88990	72810	58970	47100	36970	28300
	50	110220	91460	83050	67870	54760	43530	33940	25730
Z 50 154 Y	50	109890	90820	82290	66980	53800	42500	32810	24540
	60	94250	77640	70110	56710	45120	35140	26580	19240
	70	78310	64270	57920	46390	36440	27820	20410	14030
	80	62120	50750	45560	36100	27830	20650	14440	9070
W 40 168 Y	30	154330	128080	116420	95630	77850	62670	49780	38830
	40	137680	114230	103770	85030	68940	55160	43420	33430
	45	129350	107260	97380	79670	64420	51340	40180	30680
	50	120970	100240	90880	74250	59860	47490	36920	27910
W 50 168 Y	50	118440	97940	88770	72320	58150	46010	35660	26860
	60	101870	84070	76040	61590	49110	38370	29200	21380
	70	85100	69940	63110	50730	39990	30710	22760	15960
	80	67880	55570	49980	39770	30860	23130	16480	10780
W 50 187 Y	30	171180	142110	129200	106150	86440	69600	55290	43150
	40	152780	126810	115210	94430	76570	61270	48240	37150
	45	143530	118980	108150	88490	71570	57040	44650	34100
	50	134230	111300	100970	82490	66510	52770	41030	31020
W 60 187 Y	50	133870	110640	100240	81600	65570	51840	40150	30200
	60	115270	94970	85860	69480	55350	43200	32830	24000
	70	96270	79030	71250	57200	45040	34540	25560	17880
	80	76730	62740	56390	44810	34720	25980	18470	12020
W 60 206 Y	30	190270	157880	143490	117820	95880	77170	61290	47820
	40	170050	141000	128040	104850	84960	67960	53500	41210
	45	159890	132470	120230	98270	79420	63280	49530	37840
	50	149660	123880	112340	91630	73820	58550	45530	34440
W 70 206 Y	50	146220	120810	109430	89030	71490	56470	43680	32810
	60	125840	103670	93710	75790	60320	47030	35690	26030
	70	105030	86200	77710	62360	49050	37570	27740	19340
	80	83790	68410	61450	48810	37780	28210	19990	12940
W 70 228 Y	30	205510	170400	154790	126940	103130	82820	65600	51010
	40	183740	152140	138050	112830	91230	72760	57060	43740
	45	172720	142890	129550	105670	85170	67630	52710	40030
	50	161560	133510	120960	98430	79060	62450	48320	32690
W 75 228 Y	50	162400	133330	120330	97000	76970	59810	45190	32770
	60	138760	113270	101840	81280	63570	48370	35410	24360
	70	114620	92940	83150	65470	50190	37030	25790	16190
	80	90100	72390	64350	49750	37050	26070	16640	
W 75 240 Y	30	215560	178710	162340	133140	108180	86900	68840	53540
	40	192760	159590	144800	118340	95670	76310	59860	45900
	45	181280	149920	135920	110840	89330	70930	55290	42010
	50	169630	140160	126950	103260	82920	65500	50680	38080
W 80 240 Y	50	170270	139800	126170	101710	80700	62710	47390	34370
	60	145430	118760	106770	85230	66660	50720	37130	25550
	70	120090	97400	87160	68650	52630	38830	27040	16980
	80	94370	75840	67430	52160	38850	27330	17450	

* tabelle con capacità frigorifere a -25°C e -30°C disponibili a richiesta
 refrigerating capacities at -25°C and -30°C available upon request
 puissances frigorifiques à -25°C et -30°C disponibles sur demande
 Kälteleistungsdaten bei -25°C und -30°C sind auf Wunsch verfügbar

Con raffreddamento della testata
 With head cooling
 Avec refroidissement de la tête
 Mit Zylinderkopfkühlung

Dati elettrici

Electrical data

Données électriques

Elektrische Daten

Compressore Compressor Compresseur Verdichter	230/3/50 400/3/50 DOL				400/3/50 PWS				400/3/50 Δ - Δ				230/1/50 DOL	
	Avviamento diretto Direct on line Démarrage direct Direktanlauf				Avviamento frazionato Part winding starting Démarrage bobinage fractionné Teilwicklungsanlauf				Avviamento stella/triangolo Star/delta starting Démarrage étoile/triangle Stern/Dreieck Anlauf				Avviamento diretto Direct on line Démarrage direct Direktanlauf	
	MRA \oplus	LRA \oplus	MRA \oplus	LRA \oplus	MRA \oplus	LRA \oplus	MRA \oplus	LRA \oplus	MRA \oplus	LRA \oplus	MRA \oplus	LRA \oplus	MRA \oplus	LRA \oplus
A 0.5 4 Y	4.8	20.0	2.8	11.6								5.5	35.9	
A 0.5 5 Y	4.8	20.0	2.8	11.6								5.5	35.9	
A 0.7 5 Y	4.8	20.0	2.8	11.6								5.5	35.9	
A 0.7 6 Y	4.8	20.0	2.8	11.6								5.5	35.9	
A 1 6 Y	6.0	25.1	3.5	14.5								7.6	40.1	
A 1 7 Y	6.0	25.1	3.5	14.5								7.6	40.1	
A 1.5 7 Y	9.2	34.1	5.3	19.7								10.6	50.3	
A 1.5 8 Y	9.2	34.1	5.3	19.7								10.6	50.3	
B 1.5 9 Y	9.2	34.1	5.3	19.7								10.6	50.3	
B 1.5 10 Y	9.2	34.1	5.3	19.7								10.6	50.3	
B 2 10 Y	9.9	37.6	5.7	21.7								13.0	65.6	
C 2 11 Y	11.8	43.1	6.8	24.9								14.9	75.2	
D 2 11 Y	11.8	43.1	6.8	24.9								14.9	75.2	
C 2 12 Y	11.8	43.1	6.8	24.9								16.0	75.2	
C 3 12 Y	16.6	57.0	9.6	32.9										
D 2 13 Y	11.8	43.1	6.8	24.9										
D 3 13 Y	16.6	57.0	9.6	32.9										
D 2 15 Y	11.8	43.1	6.8	24.9										
D 3 15 Y	16.6	57.0	9.6	32.9										
D 3 16 Y	16.6	57.0	9.6	32.9										
D 4 16 Y	18.2	72.6	10.5	41.9										
F 4 16 Y	18.9	85.7	10.9	49.5					10.9	49.5	10.9	16.5		
D 3 18 Y	16.6	57.0	9.6	32.9										
D 4 18 Y	18.2	72.6	10.5	41.9										
D 3 19 Y	16.6	57.0	9.6	32.9										
F 4 19 Y	18.9	85.7	10.9	49.5					10.9	49.5	10.9	16.5		
F 5 19 Y	21.2	98.6	12.2	56.9					12.2	56.9	12.2	18.9		
F 4 24 Y	18.9	85.7	10.9	49.5					10.9	49.5	10.9	16.5		
F 5 24 Y	21.2	98.6	12.2	56.9					12.2	56.9	12.2	18.9		
Q 4 25 Y	18.9	85.7	10.9	49.5					10.9	49.5	10.9	16.5		
F 5 25 Y	21.2	98.6	12.2	56.9					12.2	56.9	12.2	18.9		
Q 5 25 Y	21.2	98.6	12.2	56.9					12.2	56.9	12.2	18.9		
Q 7 25 Y	30.0	158.0	17.5	91.4					17.5	91.4	17.5	30.4		
Q 5 28 Y	21.2	98.6	12.2	56.9					12.2	56.9	12.2	18.9		
Q 7 28 Y	30.0	158.0	17.5	91.4					17.5	91.4	17.5	30.4		
Q 5 33 Y	21.2	98.6	12.2	56.9					12.2	56.9	12.2	18.9		
S 5 33 Y	21.3	96.6	12.3	55.8	12.3	55.8	12.3	36.8	12.3	55.8	12.3	18.6		
Q 7 33 Y	30.0	158.0	17.5	91.4					17.5	91.4	17.5	30.4		
S 7 33 Y	29.4	129.0	17.0	74.6	17.0	74.6	17.0	49.2	17.0	74.6	17.0	24.8		
S 7 39 Y	29.4	129.0	17.0	74.6	17.0	74.6	17.0	49.2	17.0	74.6	17.0	24.8		
S 10 39 Y	36.4	149.0	21.0	86.1	21.0	86.1	21.0	56.8	21.0	86.1	21.0	28.7		
S 10 51 Y	36.4	149.0	21.0	86.1	21.0	86.1	21.0	56.8	21.0	86.1	21.0	28.7		
S 15 51 Y	53.7	204.0	31.0	118.0	31.0	118.0	31.0	77.8	31.0	118.0	31.0	39.3		
S 15 56 Y	53.7	204.0	31.0	118.0	31.0	118.0	31.0	77.8	31.0	118.0	31.0	39.3		
S 20 56 Y	64.1	253.0	37.0	146.0	37.0	146.0	37.0	96.7	37.0	146.0	37.0	48.6		
V 15 59 Y	53.7	204.0	31.0	118.0	31.0	118.0	31.0	77.8	31.0	118.0	31.0	39.3		
V 20 59 Y	64.1	253.0	37.0	146.0	37.0	146.0	37.0	96.7	37.0	146.0	37.0	48.6		
V 15 71 Y	53.7	204.0	31.0	118.0	31.0	118.0	31.0	77.8	31.0	118.0	31.0	39.3		
V 25 71 Y	77.9	297.0	45.0	172.0	45.0	172.0	45.0	113.0	45.0	172.0	45.0	57.3		
V 20 84 Y	64.1	253.0	37.0	146.0	37.0	146.0	37.0	96.7	37.0	146.0	37.0	48.6		
V 30 84 Y	91.8	320.0	53.0	185.0	53.0	185.0	53.0	122.0	53.0	185.0	53.0	61.6		
V 25 93 Y	77.9	297.0	45.0	172.0	45.0	172.0	45.0	113.0	45.0	172.0	45.0	57.3		
V 32 93 Y	98.7	354.0	57.0	205.0	57.0	205.0	57.0	136.0	57.0	205.0	57.0	67.0		
V 25 103 Y	77.9	297.0	45.0	172.0	45.0	172.0	45.0	113.0	45.0	172.0	45.0	57.3		
V 35 103 Y	105.0	389.0	61.0	225.0	61.0	225.0	61.0	148.0	61.0	225.0	61.0	75.0		
Z 25 106 Y	77.9	297.0	45.0	172.0	45.0	172.0	45.0	113.0	45.0	172.0	45.0	57.3		
Z 35 106 Y	105.0	389.0	61.0	225.0	61.0	225.0	61.0	148.0	61.0	225.0	61.0	75.0		
Z 30 126 Y	91.8	320.0	53.0	185.0	53.0	185.0	53.0	122.0	53.0	185.0	53.0	61.6		
Z 40 126 Y	129.0	455.0	75.0	263.0	75.0	263.0	75.0	173.0	75.0	263.0	75.0	87.6		
W 40 142 Y	155.0	520.0	90.0	300.0	90.0	300.0	90.0	198.0	90.0	300.0	90.0	100.0		
Z 40 154 Y	129.0	455.0	75.0	263.0	75.0	263.0	75.0	173.0	75.0	263.0	75.0	87.6		
Z 50 154 Y	160.0	533.0	92.5	308.0	92.5	308.0	92.5	203.0	92.5	308.0	92.5	102.0		
W 40 168 Y	155.0	520.0	90.0	300.0	90.0	300.0	90.0	198.0	90.0	300.0	90.0	100.0		
W 50 168 Y	174.0	543.0	101.0	314.0	101.0	314.0	101.0	208.0	101.0	314.0	101.0	104.0		
W 50 187 Y	174.0	543.0	101.0	314.0	101.0	314.0	101.0	208.0	101.0	314.0	101.0	104.0		
W 60 187 Y	197.0	633.0	114.0	366.0	114.0	366.0	114.0	241.0	114.0	366.0	114.0	122.0		
W 60 206 Y	197.0	633.0	114.0	366.0	114.0	366.0	114.0	241.0	114.0	366.0	114.0	122.0		
W 70 206 Y	216.0	822.0	125.0	475.0	125.0	475.0	125.0	313.0	125.0	475.0	125.0	158.0		
W 70 228 Y	216.0	822.0	125.0	475.0	125.0	475.0	125.0	313.0	125.0	475.0	125.0	158.0		
W 75 228 Y	235.0	881.0	136.0	509.0	136.0	509.0	136.0	340.0	136.0	509.0	136.0	169.0		
W 75 240 Y	235.0	881.0	136.0	509.0	136.0	509.0	136.0	340.0	136.0	509.0	136.0	169.0		
W 80 240 Y	235.0	881.0	136.0	509.0	136.0	509.0	136.0	340.0	136.0	509.0	136.0	169.0		

FCA101-07

motore elettrico standard
motore elettrico a richiesta

standard electric motor
electric motor on request

moteur électrique standard
moteur électrique sur demande

Standardmotor
Sondermotor auf Anfrage

\oplus MRA Massima corrente di funzionamento A
LRA Corrente a rotore bloccato A

\oplus MRA Maximum operating current A
LRA Locked rotor current A

\oplus MRA Intensité maximum de fonctionnement A
LRA Courant rotor bloqué A

\oplus MRA Maximaler Betriebsstrom A
LRA Anlaufstrom A

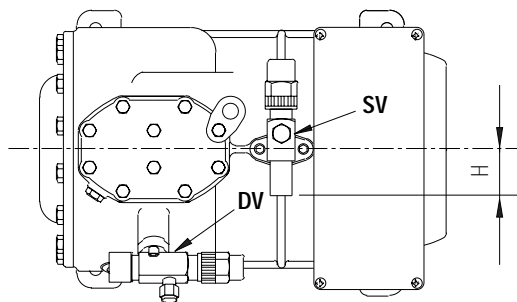
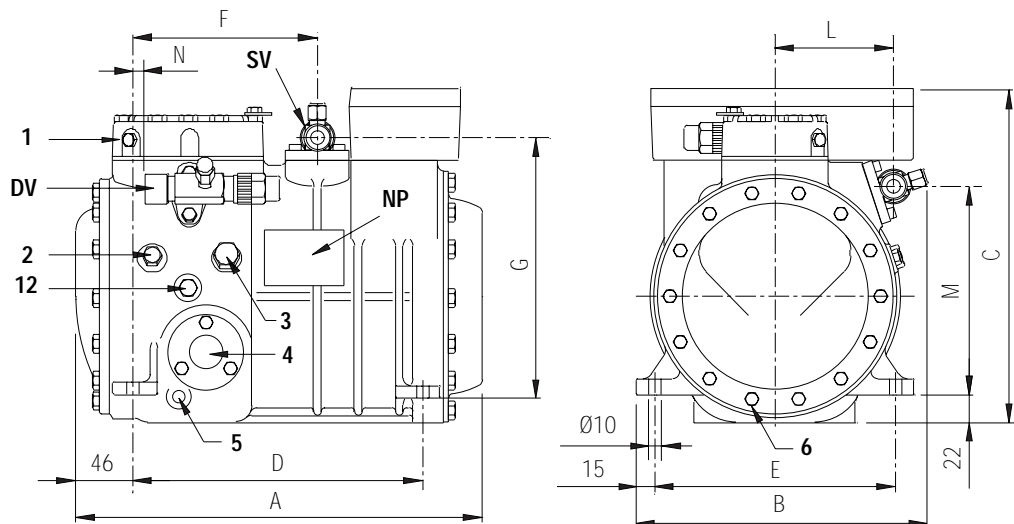

Supporto antivibrante

Vibration absorber

Support anti-vibrations

Vibrationsabsorber

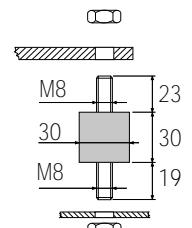

Serie	Series	A
Série	Reihe	

Compressore Compressor Compresseur Verdichter	Rubinetto aspirazione Suction valve Soupape d'aspiration Saugventil		Rubinetto compressione Discharge valve Soupape de refoulement Druckventil		Lunghezza Length Longueur Länge	Larghezza Width Largeur Breite	Altezza Height Hauteur Höhe	Interassi di fissaggio Base mounting Trous de fixation Befestigungslöcher			Rubinetto aspirazione Suction valve Soupape d'aspiration Saugventil			Rubinetto compressione Discharge valve Soupape de refoulement Druckventil		
	Ø"	Ø mm	Ø"	Ø mm				D mm	E mm	F mm	G mm	H mm	L mm	M mm	N mm	
	A	B	C	D	E	F	G	H	L	M	N					
A 0.5 4 Y	5/8	15.8	1/2	12.7	315	236	273	234	194	150	210	37	95	168	17	
A 0.5 5 Y	5/8	15.8	1/2	12.7	315	236	273	234	194	150	210	37	95	168	17	
A 0.7 5 Y	5/8	15.8	1/2	12.7	315	236	273	234	194	150	210	37	95	168	17	
A 0.7 6 Y	5/8	15.8	1/2	12.7	315	236	273	234	194	150	210	37	95	168	17	
A 1 6 Y	5/8	15.8	1/2	12.7	315	236	273	234	194	150	210	37	95	168	17	
A 1 7 Y	5/8	15.8	1/2	12.7	315	236	273	234	194	150	210	37	95	168	17	
A 1.5 7 Y	5/8	15.8	1/2	12.7	315	236	273	234	194	150	210	37	95	168	17	
A 1.5 8 Y	5/8	15.8	1/2	12.7	315	236	273	234	194	150	210	37	95	168	17	
A 1.5 7 Y 1ph	5/8	15.8	1/2	12.7	328	236	251	234	194	150	210	37	95	168	17	
A 1.5 8 Y 1ph	5/8	15.8	1/2	12.7	328	236	251	234	194	150	210	37	95	168	17	

1	tappo di alta pressione	high pressure plug	bouchon haute pression	Stopfen Druckseite
2	tappo di bassa pressione	low pressure plug	bouchon basse pression	Stopfen Saugseite
3	tappo di carico olio	oil charge plug	bouchon charge d'huile	Stopfen Ölfüllung
4	spia livello olio	oil level sight glass	voyant de niveau huile	Ölschauglas
5	sede resistenza carter	crankcase heater seat	doigt de gant pour résistance de carter	Pos. für Ölumpfheizung
6	tappo scarico olio	oil drain plug	bouchon vidange d'huile	Stopfen Olablass
12	tappo ritorno olio	oil return plug	bouchon retour d'huile	Stopfen Ölrückführung
DV	rubinetto di compressione	discharge valve	soupape de refoulement	Druckventil
NP	targhetta	name plate	plaque signalétique	Verdichtertypschild
SV	rubinetto di aspirazione	suction valve	soupape d'aspiration	Saugventil

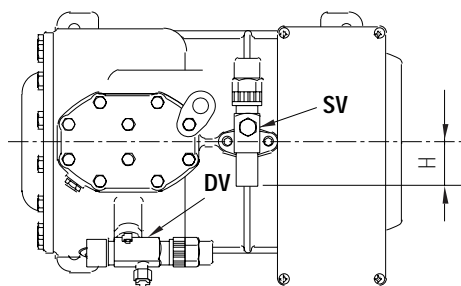
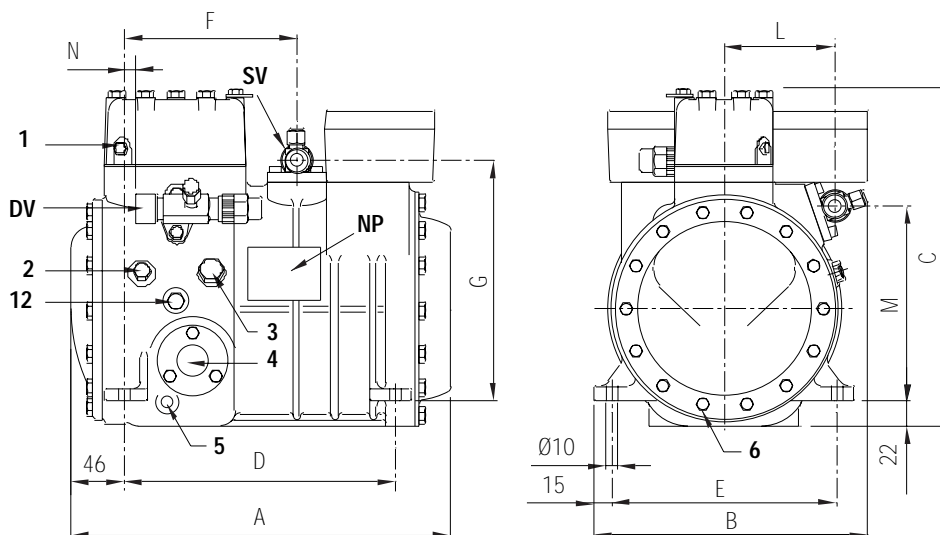

Supporto antivibrante

Vibration absorber

Support anti-vibrations

Vibrationsabsorber

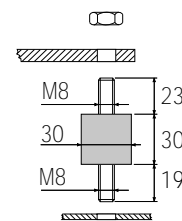
Série Series
Série Reihe **B-C**

Compressore Compressor Compresseur Verdichter	Rubinetto aspirazione Suction valve Soupape d'aspiration Saugventil		Rubinetto compressione Discharge valve Soupape de refoulement Druckventil		Lunghezza Length Longueur Länge	Larghezza Width Largeur Breite	Altezza Height Hauteur Höhe	Interassi di fissaggio Base mounting Trous de fixation Befestigungslöcher		Rubinetto aspirazione Suction valve Soupape d'aspiration Saugventil			Rubinetto compressione Discharge valve Soupape de refoulement Druckventil		
	Ø"	Ø mm	Ø"	Ø mm	A mm	B mm	C mm	D mm	E mm	F mm	G mm	H mm	L mm	M mm	N mm
B 1.5 9 Y	5/8	15.8	1/2	12.7	315	236	294	234	194	150	207	37	95	168	17
B 1.5 10 Y	5/8	15.8	1/2	12.7	315	236	294	234	194	150	207	37	95	168	17
B 2 10 Y	3/4	19.0	5/8	15.8	328	236	294	234	194	150	207	37	95	168	15
B 1.5 9 Y	1ph 5/8	15.8	1/2	12.7	328	236	294	234	194	150	207	37	95	168	17
B 1.5 10 Y	1ph 5/8	15.8	1/2	12.7	328	236	294	234	194	150	207	37	95	168	17
B 2 10 Y	1ph 3/4	19.0	5/8	15.8	328	236	294	234	194	150	207	37	95	168	15
C 2 11 Y	1 1/8	28.6	5/8	15.8	334	236	294	234	194	143	213	53	95	168	18
C 2 12 Y	1 1/8	28.6	5/8	15.8	334	236	294	234	194	143	213	53	95	168	18
C 2 11 Y	1ph 1 1/8	28.6	5/8	15.8	361	236	294	234	194	143	213	53	95	168	18
C 2 12 Y	1ph 1 1/8	28.6	5/8	15.8	361	236	294	234	194	143	213	53	95	168	18
C 3 12 Y	1 1/8	28.6	5/8	15.8	361	236	294	234	194	143	213	53	95	168	18

1	tappo di alta pressione	high pressure plug	bouchon haute pression	Stopfen Druckseite
2	tappo di bassa pressione	low pressure plug	bouchon basse pression	Stopfen Saugseite
3	tappo di carico olio	oil charge plug	bouchon charge d'huile	Stopfen Ölfüllung
4	spia livello olio	oil level sight glass	voyant de niveau huile	Ölschauglas
5	sede resistenza carter	crankcase heater seat	doigt de gant pour résistance de carter	Pos. für Ölsumpfeheizung
6	tappo scarico olio	oil drain plug	bouchon vidange d'huile	Stopfen Ölablass
12	tappo ritorno olio	oil return plug	bouchon retour d'huile	Stopfen Ölrückführung
DV	rubinetto di compressione	discharge valve	soupape de refoulement	Druckventil
NP	targhetta	name plate	plaque signalétique	Verdichtertypschild
SV	rubinetto di aspirazione	suction valve	soupape d'aspiration	Saugventil

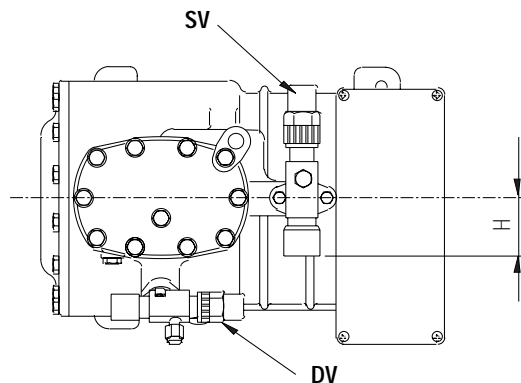
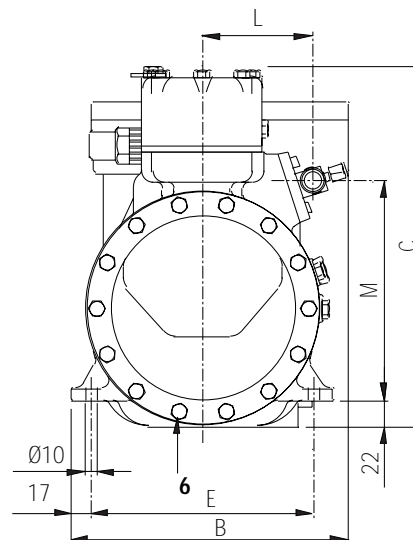
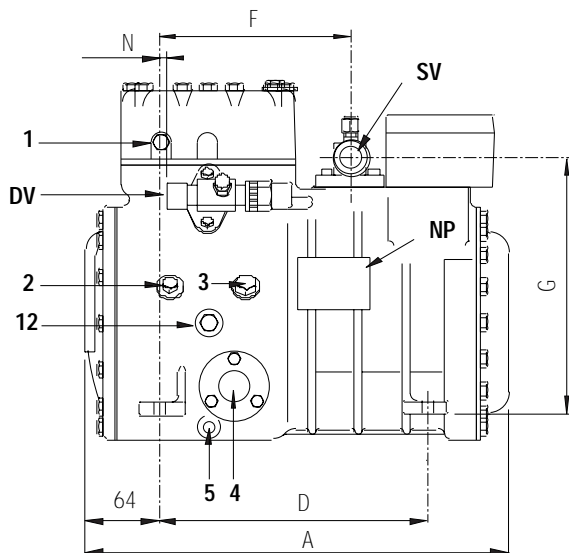

Supporto antivibrante

Vibration absorber

Support anti-vibrations

Vibrationsabsorber

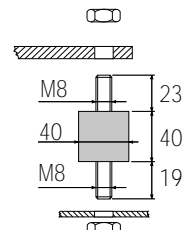

Serie	Series	D
Série	Reihe	

FCAT01-07

Compressore Compressor Compresseur Verdichter	Rubinetto aspirazione Suction valve Soupape d'aspiration Saugventil		Rubinetto compressione Discharge valve Soupape de refoulement Druckventil		Lunghezza Length Longueur Länge	Larghezza Width Largeur Breite	Altezza Height Hauteur Höhe	Interassi di fissaggio Base mounting Trous de fixation Befestigungslöcher		Rubinetto aspirazione Suction valve Soupape d'aspiration Saugventil			Rubinetto compressione Discharge valve Soupape de refoulement Druckventil		
	Ø"	Ø mm	Ø"	Ø mm				D mm	E mm	F mm	G mm	H mm	L mm	M mm	N mm
	A	B	C	D				E	F	G	H	L	M	N	
D 2 11 Y	7/8	22.2	5/8	15.8	353	240	296	234	194	167	223	49	96	192	6
D 2 13 Y	7/8	22.2	5/8	15.8	353	240	296	234	194	167	223	49	96	192	6
D 2 11 Y 1ph	7/8	22.2	5/8	15.8	369	240	314	234	194	167	223	49	96	192	6
D 2 13 Y 1ph	7/8	22.2	5/8	15.8	369	240	314	234	194	167	223	49	96	192	6
D 3 13 Y	1 1/8	28.6	5/8	15.8	369	240	314	234	194	167	223	49	96	192	6
D 2 15 Y	7/8	22.2	5/8	15.8	353	240	296	234	194	167	223	49	96	192	6
D 3 15 Y	1 1/8	28.6	5/8	15.8	369	240	314	234	194	167	223	49	96	192	6
D 3 16 Y	1 1/8	28.6	5/8	15.8	369	240	314	234	194	167	223	49	96	192	6
D 4 16 Y	1 1/8	28.6	3/4	19.0	374	240	314	234	194	167	223	49	96	192	6
D 3 18 Y	1 1/8	28.6	5/8	15.8	369	240	314	234	194	167	223	49	96	192	6
D 4 18 Y	1 1/8	28.6	3/4	19.0	374	240	314	234	194	167	223	49	96	192	6
D 3 19 Y	1 1/8	28.6	5/8	15.8	369	240	314	234	194	167	223	49	96	192	6

1	tappo di alta pressione	high pressure plug	bouchon haute pression	Stopfen Druckseite
2	tappo di bassa pressione	low pressure plug	bouchon basse pression	Stopfen Saugseite
3	tappo di carico olio	oil charge plug	bouchon charge d'huile	Stopfen Ölfüllung
4	spia livello olio	oil level sight glass	voyant de niveau huile	Ölschauglas
5	sede resistenza carter	crankcase heater seat	doigt de gant pour résistance de carter	Pos. für Ölsumpfeheizung
6	tappo scarico olio	oil drain plug	bouchon vidange d'huile	Stopfen Ölablass
12	tappo ritorno olio	oil return plug	bouchon retour d'huile	Stopfen Ölrückführung
DV	rubinetto di compressione	discharge valve	soupape de refoulement	Druckventil
NP	targhetta	name plate	plaque signalétique	Verdichtertypschild
SV	rubinetto di aspirazione	suction valve	soupape d'aspiration	Saugventil

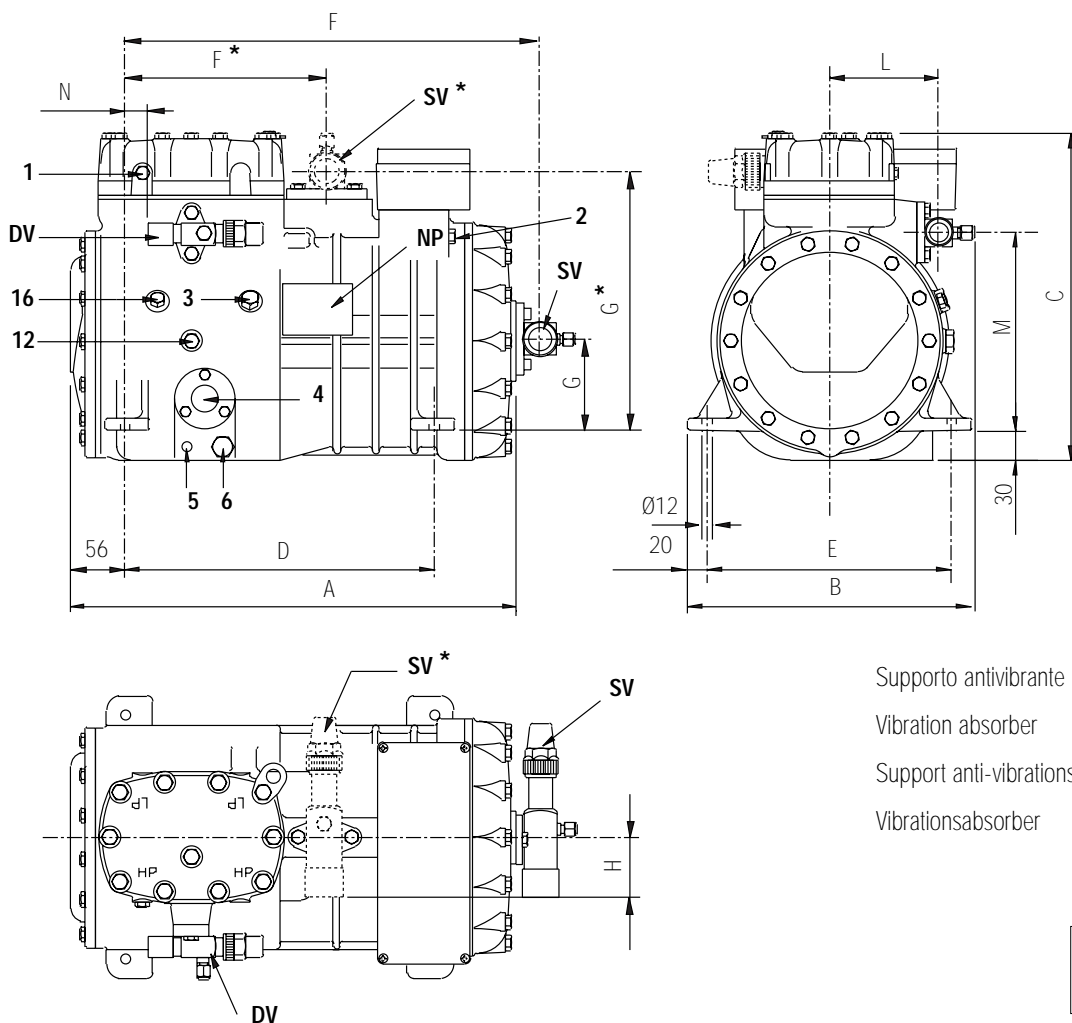

FCAT01-07

Compressore Compressor Compresseur Verdichter	Rubinetto aspirazione Suction valve Soupape d'aspiration Saugventil		Rubinetto compressione Discharge valve Soupape de refoulement Druckventil		Lunghezza Length Longueur Länge	Larghezza Width Largeur Breite	Altezza Height Hauteur Höhe	Interassi di fissaggio Base mounting Trous de fixation Befestigungslöcher		Rubinetto aspirazione Suction valve Soupape d'aspiration Saugventil			Rubinetto compressione Discharge valve Soupape de refoulement Druckventil		
	Ø"	Ø mm	Ø"	Ø mm	A mm	B mm	C mm	D mm	E mm	F mm	G mm	H mm	L mm	M mm	N mm
F 4 16 Y	1 1/8	28.6	3/4	19.0	515	286	336	312	246	424	90	49	108	192	24
F 4 19 Y	1 1/8	28.6	3/4	19.0	515	286	336	312	246	424	90	49	108	192	24
F 5 19 Y	1 1/8	28.6	3/4	19.0	515	286	336	312	246	424	90	49	108	192	24
F 5 24 Y	1 1/8	28.6	7/8	22.2	515	286	336	312	246	424	90	49	112	192	17
F 4 24 Y*	1 1/8	28.6	3/4	19.0	436	286	336	312	246	203	260	49	108	198	24
F 5 25 Y*	1 1/8	28.6	7/8	22.2	436	286	336	312	246	203	260	62	112	198	17

1	tappo di alta pressione	high pressure plug	bouchon haute pression	Stopfen Druckseite
2	tappo di bassa pressione	low pressure plug	bouchon basse pression	Stopfen Saugseite
3	tappo di carico olio	oil charge plug	bouchon charge d'huile	Stopfen Ölfüllung
4	spia livello olio	oil level sight glass	voyant de niveau huile	Ölschauglas
5	sede resistenza carter	crankcase heater seat	doigt de gant pour résistance de carter	Pos. für Ölsumpfheizung
6	tappo scarico olio	oil drain plug	bouchon vidange d'huile	Stopfen Ölablass
12	tappo ritorno olio	oil return plug	bouchon retour d'huile	Stopfen Ölrückführung
16	tappo pressione carter	crankcase pressure plug	bouchon pression de carter	Stopfen für Drucksumpf
DV	rubinetto di compressione	discharge valve	soupape de refoulement	Druckventil
NP	targhetta	name plate	plaque signalétique	Verdichtertypschild
SV	rubinetto di aspirazione	suction valve	soupape d'aspiration	Saugventil

(*) posizione del rubinetto di aspirazione per i modelli F 4 24 Y, F 5 25 Y
 suction valve location for models F 4 24 Y, F 5 25 Y
 position de la soupape d'aspiration pour les modèles F 4 24 Y, F 5 25 Y
 Stellung des Saugventiles für die Modelle F 4 24 Y, F 5 25 Y

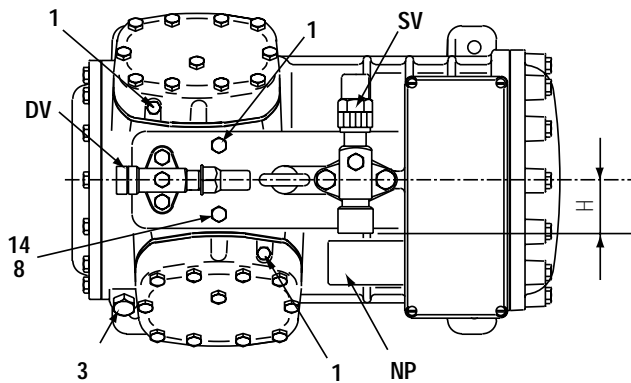
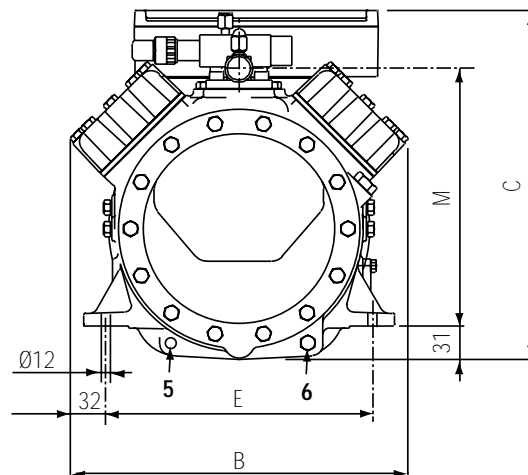
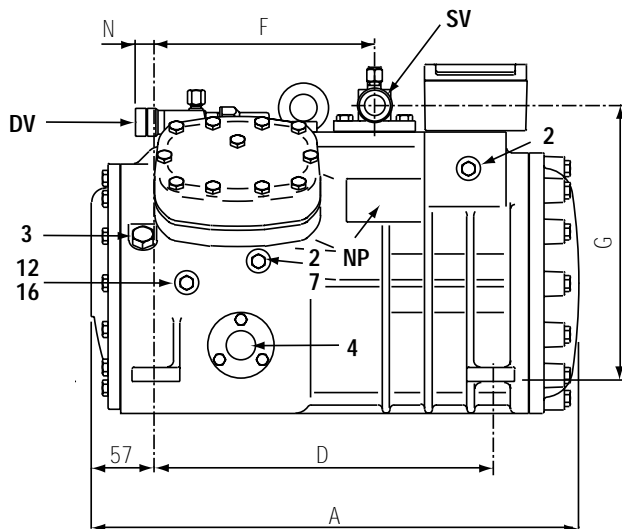

Supporto antivibrante
Vibration absorber
Support anti-vibrations
Vibrationsabsorber

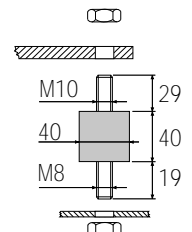

Serie Series
Série Reihe **Q**

Compressore Compressor Compresseur Verdichter	Rubinetto aspirazione Suction valve Soupape d'aspiration Saugventil		Rubinetto compressione Discharge valve Soupape de refoulement Druckventil		Lunghezza Length Longueur Länge	Larghezza Width Largeur Breite	Altezza Height Hauteur Höhe	Interassi di fissaggio Base mounting Trous de fixation Befestigungslöcher		Rubinetto aspirazione Suction valve Soupape d'aspiration Saugventil			Rubinetto compressione Discharge valve Soupape de refoulement Druckventil	
	Ø"	Ø mm	Ø"	Ø mm				D	E	F	G	H	M	N
	A	B	C	D				E	F	G	H	M	N	
Q 4 25 Y	1 1/8	28.6	3/4	19.0	448	310	324	312	246	203	256	49	240	17
Q 5 25 Y	1 1/8	28.6	7/8	22.2	448	310	324	312	246	203	256	49	244	24
Q 7 25 Y	1 1/8	28.6	7/8	22.2	448	310	324	312	246	203	256	49	244	24
Q 5 28 Y	1 3/8	35.0	7/8	22.2	448	310	324	312	246	203	258	60	244	24
Q 7 28 Y	1 3/8	35.0	1 1/8	28.6	448	310	324	312	246	203	258	60	244	24
Q 5 33 Y	1 3/8	35.0	1 1/8	28.6	448	310	324	312	246	203	258	60	244	24
Q 7 33 Y	1 3/8	35.0	1 1/8	28.6	448	310	324	312	246	203	258	60	244	24

1	tappo di alta pressione	high pressure plug	bouchon haute pression	Stopfen Druckseite
2	tappo di bassa pressione	low pressure plug	bouchon basse pression	Stopfen Saugseite
3	tappo di carico olio	oil charge plug	bouchon charge d'huile	Stopfen Ölfüllung
4	spia livello olio	oil level sight glass	voyant de niveau huile	Ölschauglas
5	sede resistenza carter	crankcase heater seat	doigt de gant pour résistance de carter	Pos. für Ölumpfheizung
6	tappo scarico olio	oil drain plug	bouchon vidange d'huile	Stopfen Ölablass
7	attacco per valvola iniezione liquido	liquid injection valve plug	bouchon électrov.injection de liquide	Stopfen Flüssigkeitseinspritzung
8	attacco per sensore iniezione liquido	liquid injection sensor plug	bouchon sensor injection de liquide	Stopfen Sensor
12	tappo ritorno olio	oil return plug	bouchon retour d'huile	Stopfen Ölrückführung
14	tappo per sensore massima temp. scarico	max. discharge temperature sensor plug	bouchon sensor max.temp.de refoulement	Stopfen für Druckgasfühler
16	tappo pressione carter	crankcase pressure plug	bouchon pression de carter	Stopfen für Drucksumpf
DV	rubinetto di compressione	discharge valve	soupape de refoulement	Druckventil
NP	targhetta	name plate	plaque signalétique	Verdichtertypschild
SV	rubinetto di aspirazione	suction valve	soupape d'aspiration	Saugventil

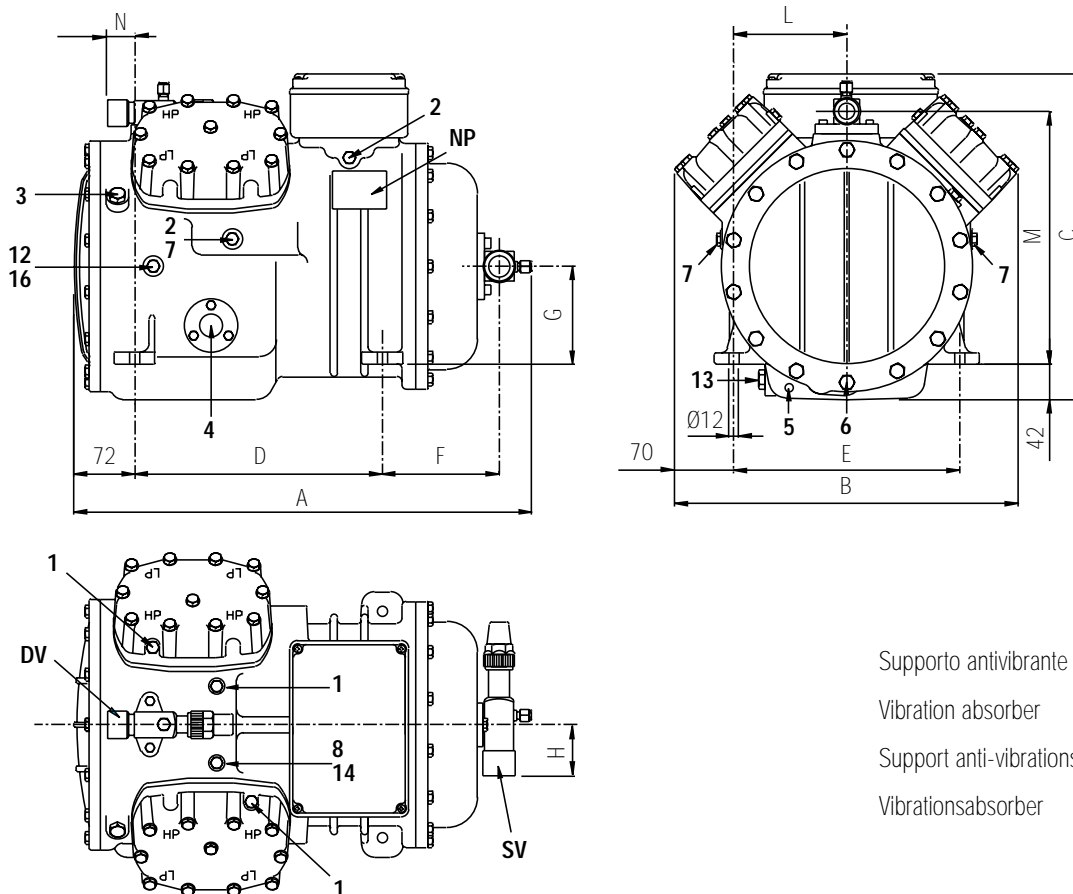

Supporto antivibrante

Vibration absorber

Support anti-vibrations

Vibrationsabsorber

Serie	Series	S
Série	Reihe	

Compressore Compressor Compresseur Verdichter	Rubinetto aspirazione Suction valve Soupape d'aspiration Saugventil		Rubinetto compressione Discharge valve Soupape de refoulement Druckventil		Lunghezza Length Longueur Länge	Larghezza Width Largeur Breite	Altezza Height Hauteur Höhe	Interassi di fissaggio Base mounting Trous de fixation Befestigungslöcher		Rubinetto aspirazione Suction valve Soupape d'aspiration Saugventil			Rubinetto compressione Discharge valve Soupape de refoulement Druckventil		
	Ø"	Ø mm	Ø"	Ø mm	A mm	B mm	C mm	D mm	E mm	F mm	G mm	H mm	L mm	M mm	N mm
S 5 33 Y	1 3/8	35.0	1 1/8	28.6	544	405	384	292	266	138	115	60	133	298	20
S 7 33 Y	1 3/8	35.0	1 1/8	28.6	544	405	384	292	266	138	115	60	133	298	20
S 7 39 Y	1 3/8	35.0	1 1/8	28.6	544	405	384	292	266	138	115	60	133	298	20
S 10 39 Y	1 3/8	35.0	1 1/8	28.6	544	405	384	292	266	138	115	60	133	298	20
S 10 51 Y	1 3/8	35.0	1 1/8	28.6	544	405	384	292	266	138	115	60	133	298	20
S 15 51 Y	1 5/8	42.0	1 1/8	28.6	550	405	384	292	266	138	115	123	133	298	20
S 15 56 Y	1 5/8	42.0	1 1/8	28.6	550	405	384	292	266	138	115	123	133	298	20
S 20 56 Y	1 5/8	42.0	1 1/8	28.6	550	405	384	292	266	138	115	123	133	298	20

1	tappo di alta pressione	high pressure plug	bouchon haute pression	Stopfen Druckseite
2	tappo di bassa pressione	low pressure plug	bouchon basse pression	Stopfen Saugseite
3	tappo di carico olio	oil charge plug	bouchon charge d'huile	Stopfen Ölfüllung
4	spia livello olio	oil level sight glass	voyant de niveau huile	Ölschauglas
5	sede resistenza carter	crankcase heater seat	doigt de gant pour résistance de carter	Pos. für Ölsumpfheizung
6	tappo scarico olio	oil drain plug	bouchon vidange d'huile	Stopfen Ölabblass
7	attacco per valvola iniezione liquido	liquid injection valve plug	bouchon électrov.injection de liquide	Stopfen Flüssigkeitseinspritzung
8	attacco per sensore iniezione liquido	liquid injection sensor plug	bouchon sensor injection de liquide	Stopfen Sensor
12	tappo ritorno olio	oil return plug	bouchon retour d'huile	Stopfen Ölrückführung
13	tappo magnetico	magnetic plug	bouchon magnétique	Magnetstopfen
14	tappo per sensore massima temp. scarico	max. discharge temperature sensor plug	bouchon sensor max.temp.de refoulement	Stopfen für Druckgasfühler
16	tappo pressione carter	crankcase pressure plug	bouchon pression de carter	Stopfen für Drucksumpf
DV	rubinetto di compressione	discharge valve	soupape de refoulement	Druckventil
NP	targhetta	name plate	plaque signalétique	Verdichtertypschild
SV	rubinetto di aspirazione	suction valve	soupape d'aspiration	Saugventil

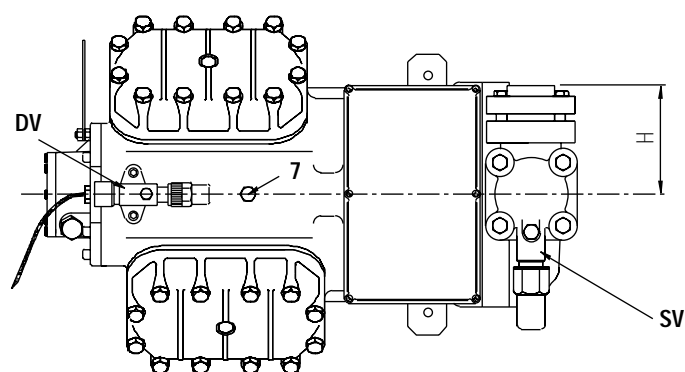
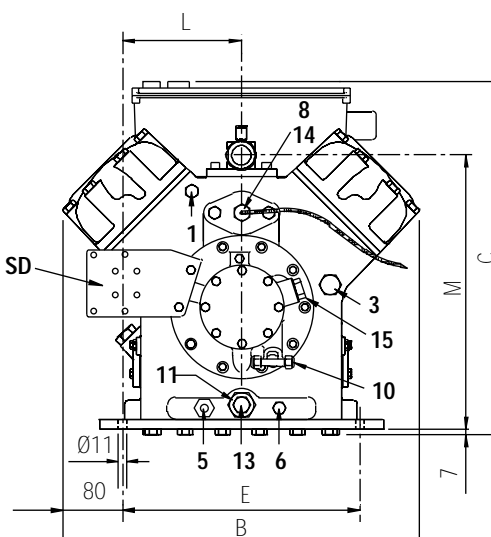
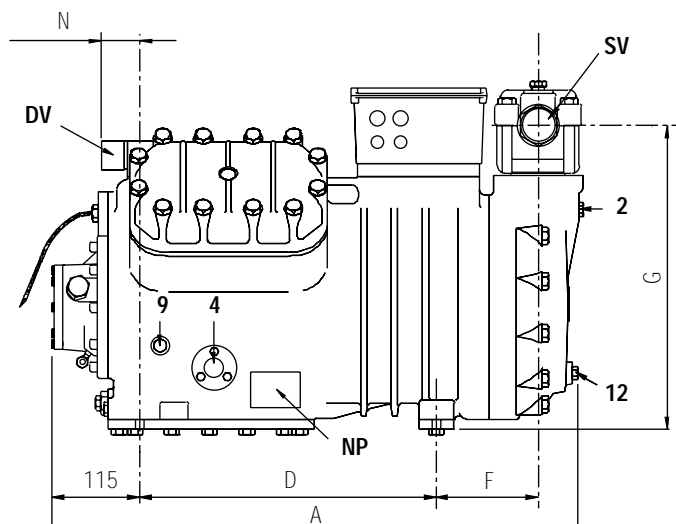

Supporto antivibrante

Vibration absorber

Support anti-vibrations

Vibrationsabsorber

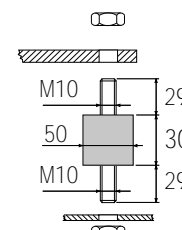

Serie	Series	V
Série	Reihe	

Compressore Compressor Compresseur Verdichter	Rubinetto aspirazione Suction valve Soupape d'aspiration Saugventil		Rubinetto compressione Discharge valve Soupape de refoulement Druckventil		Lunghezza Length Longueur Länge	Larghezza Width Largeur Breite	Altezza Height Hauteur Höhe	Interassi di fissaggio Base mounting Trous de fixation Befestigungslöcher		Rubinetto aspirazione Suction valve Soupape d'aspiration Saugventil			Rubinetto compressione Discharge valve Soupape de refoulement Druckventil		
	Ø"	Ø mm	Ø"	Ø mm				D mm	E mm	F mm	G mm	H mm	L mm	M mm	N mm
V 15 59 Y	1 5/8	42.0	1 1/8	28.6	666	465	442	381	305	120	374	123	152	354	36
V 20 59 Y	1 5/8	42.0	1 1/8	28.6	666	465	442	381	305	120	374	123	152	354	36
V 15 71 Y	1 5/8	42.0	1 1/8	28.6	666	465	442	381	305	120	374	123	152	354	36
V 25 71 Y	2 1/8	54.0	1 3/8	35.0	687	465	460	381	305	133	390	136	152	356	47
V 20 84 Y	1 5/8	42.0	1 1/8	28.6	666	465	442	381	305	120	374	123	152	354	36
V 30 84 Y	2 1/8	54.0	1 3/8	35.0	687	465	460	381	305	133	390	136	152	356	47
V 25 93 Y	2 1/8	54.0	1 3/8	35.0	687	465	460	381	305	133	390	136	152	356	47
V 32 93 Y	2 1/8	54.0	1 3/8	35.0	755	465	460	381	305	178	388	136	152	356	47
V 25 103 Y	2 1/8	54.0	1 3/8	35.0	687	465	460	381	305	133	390	136	152	356	47
V 35 103 Y	2 1/8	54.0	1 3/8	35.0	755	465	460	381	305	178	388	136	152	356	47

1	tappo di alta pressione	high pressure plug	bouchon haute pression	Stopfen Druckseite
2	tappo di bassa pressione	low pressure plug	bouchon basse pression	Stopfen Saugseite
3	tappo di carico olio	oil charge plug	bouchon charge d'huile	Stopfen Ölfüllung
4	spia livello olio	oil level sight glass	voyant de niveau huile	Ölschauglas
5	sede resistenza carter	crankcase heater seat	doigt de gant pour résistance de carter	Pos. für Ölsumpfeizung
6	tappo scarico olio	oil drain plug	bouchon vidange d'huile	Stopfen Ölablass
7	attacco per valvola iniezione liquido	liquid injection valve plug	bouchon electrov.injection de liquide	Stopfen Flüssigkeitseinspritzung
8	attacco per sensore iniezione liquido	liquid injection sensor plug	bouchon sensor injection de liquide	Stopfen Sensor
9	attacco pressostato diff. olio (b.p.)	oil pressure switch connection (l.p.)	raccord pressostat diff. huile (b.p.)	Öldruckschalter Niederdruckanschluss
10	attacco pressostato diff. olio (a.p.)	oil pressure switch connection (h.p.)	raccord pressostat diff. huile (h.p.)	Öldruckschalter Hochdruckanschluss
11	filtro olio	oil filter	filtre à huile	Ölfilter
12	tappo ritorno olio	oil return plug	bouchon retour d'huile	Stopfen Ölrückführung
13	tappo magnetico	magnetic plug	bouchon magnétique	Magnetstopfen
14	sensore massima temp. scarico	max. discharge temperature sensor	sensor max. temp. de refoulement	Druckgasfühler
15	attacco pressostato olio elettronico	electronic oil pressure switch connection	raccord pressostat diff. huile électronique	Elektronische Öldruckschalteranschluss
DV	rubinetto di compressione	discharge valve	soupape de refoulement	Druckventil
NP	targhetta	name plate	plaque signalétique	Verdichtertypschild
SD	staffetta di fissaggio del pressostato	oil pressure switch mounting bracket	support pour pressostat diff. huile	Öldruckschalterbügel
SV	rubinetto di aspirazione	suction valve	soupape d'aspiration	Saugventil

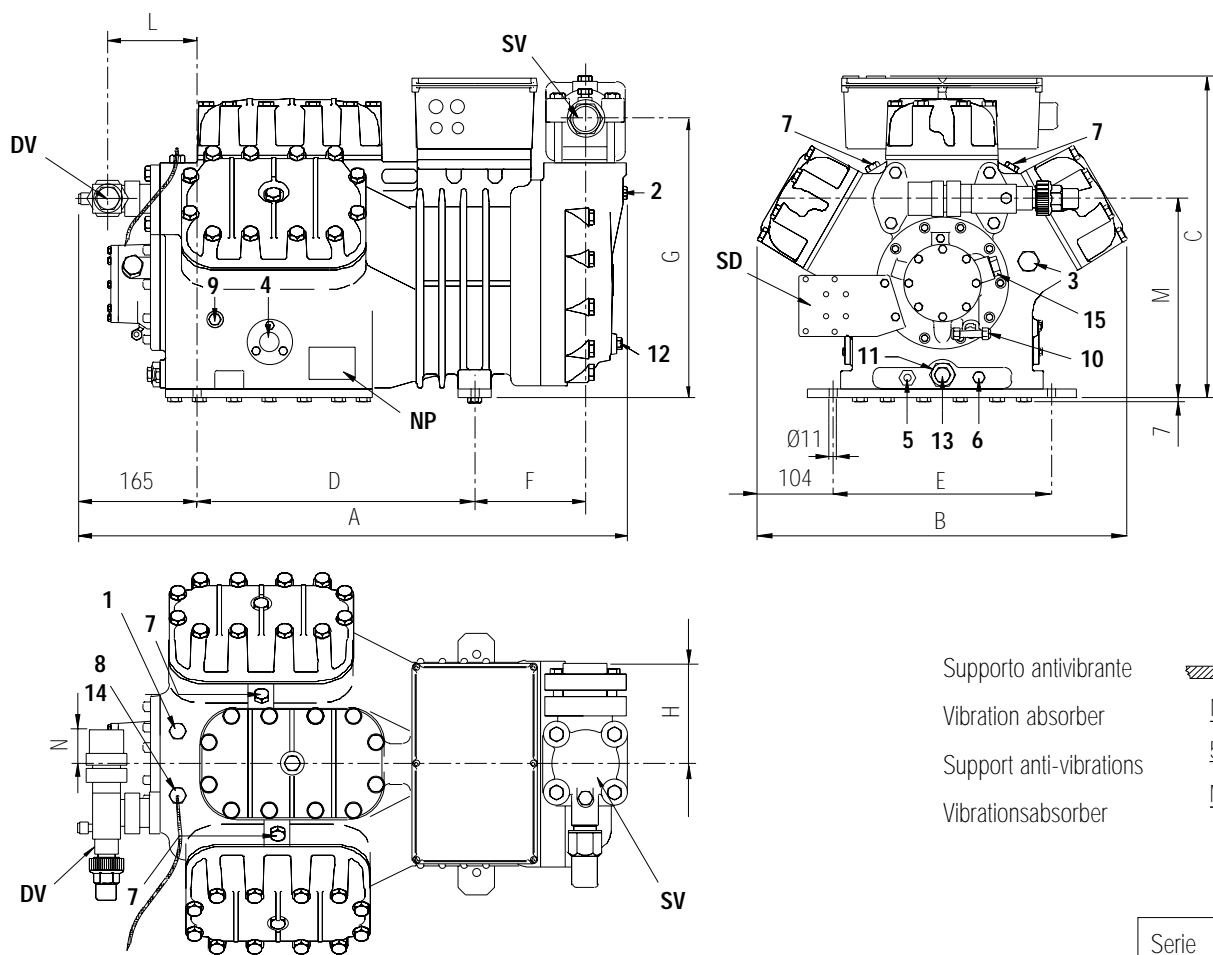

FCAT01-07

Compressore Compressor Compresseur Verdichter	Rubinetto aspirazione Suction valve Soupape d'aspiration Saugventil		Rubinetto compressione Discharge valve Soupape de refoulement Druckventil		Lunghezza Length Longueur Länge	Larghezza Width Largeur Breite	Altezza Height Hauteur Höhe	Interassi di fissaggio Base mounting Trous de fixation Befestigungslöcher		Rubinetto aspirazione Suction valve Soupape d'aspiration Saugventil			Rubinetto compressione Discharge valve Soupape de refoulement Druckventil		
	Ø"	Ø mm	Ø"	Ø mm	A mm	B mm	C mm	D mm	E mm	F mm	G mm	H mm	L mm	M mm	N mm
Z 25 106 Y	2 1/8	54.0	1 3/8	35.0	768	512	446	381	305	154	388	136	125	277	47.5
Z 35 106 Y	2 1/8	54.0	1 3/8	35.0	822	512	446	381	305	178	388	136	125	277	47.5

1	tappo di alta pressione	high pressure plug	bouchon haute pression	Stopfen Druckseite
2	tappo di bassa pressione	low pressure plug	bouchon basse pression	Stopfen Saugseite
3	tappo di carico olio	oil charge plug	bouchon charge d'huile	Stopfen Ölfüllung
4	spia livello olio	oil level sight glass	voyant de niveau huile	Ölschauglas
5	sede resistenza carter	crankcase heater seat	doigt de gant pour résistance de carter	Pos. für Ölpumpeheizung
6	tappo scarico olio	oil drain plug	bouchon vidange d'huile	Stopfen Ölablass
7	attacco per valvola iniezione liquido	liquid injection valve plug	bouchon électrov.injection de liquide	Stopfen Flüssigkeitseinspritzung
8	attacco per sensore iniezione liquido	liquid injection sensor plug	bouchon sensor injection de liquide	Stopfen Sensor
9	attacco pressostato diff. olio (b.p.)	oil pressure switch connection (l.p.)	raccord pressostat diff. huile (b.p.)	Öldruckschalter Niederdruckanschluss
10	attacco pressostato diff. olio (a.p.)	oil pressure switch connection (h.p.)	raccord pressostat diff. huile (h.p.)	Öldruckschalter Hochdruckanschluss
11	filtro olio	oil filter	filtre à huile	Ölfilter
12	tappo ritorno olio	oil return plug	bouchon retour d'huile	Stopfen Ölrückführung
13	tappo magnetico	magnetic plug	bouchon magnétique	Magnetstopfen
14	sensore massima temp. scarico	max. discharge temperature sensor	sensor max. temp. de refoulement	Druckgasfühler
15	attacco pressostato olio elettronico	electronic oil pressure switch connection	raccord pressostat diff. huile électronique	Elektronische Öldruckschalteranschluss
DV	rubinetto di compressione	discharge valve	soupape de refoulement	Druckventil
NP	targhetta	name plate	plaque signalétique	Verdichtertypschild
SD	staffetta di fissaggio del pressostato	oil pressure switch mounting bracket	support pour pressostat diff. huile	Öldruckschalterbügel
SV	rubinetto di aspirazione	suction valve	soupape d'aspiration	Saugventil

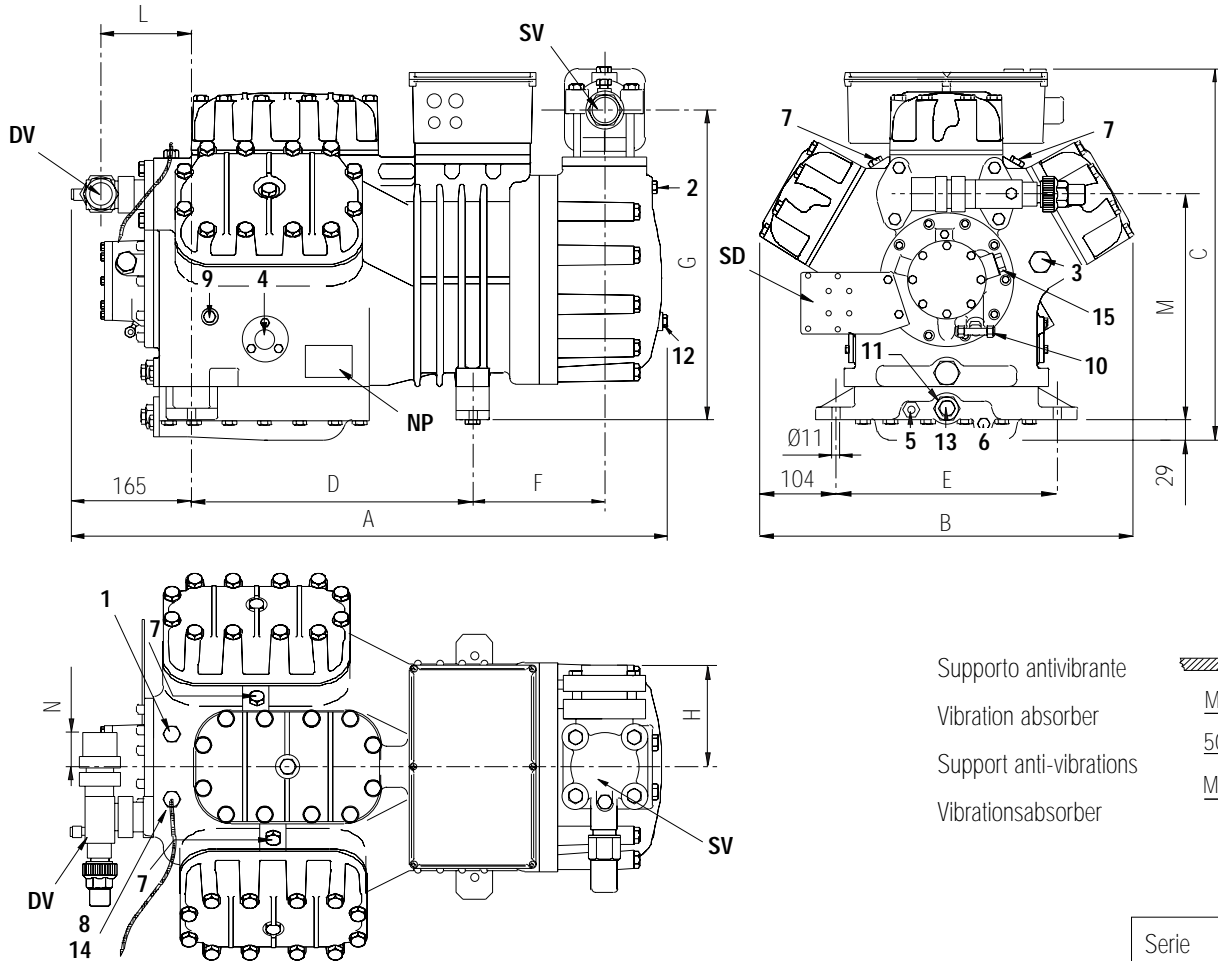

Supporto antivibrante
Vibration absorber
Support anti-vibrations
Vibrationsabsorber

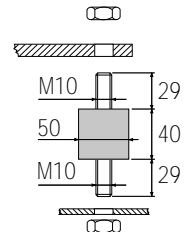

Serie Series
Série Reihe **Z**

Compressore Compressor Compresseur Verdichter	Rubinetto aspirazione Suction valve Soupape d'aspiration Saugventil		Rubinetto compressione Discharge valve Soupape de refoulement Druckventil		Lunghezza Length Longueur Länge	Larghezza Width Largeur Breite	Altezza Height Hauteur Höhe	Interassi di fissaggio Base mounting Trous de fixation Befestigungslöcher		Rubinetto aspirazione Suction valve Soupape d'aspiration Saugventil			Rubinetto compressione Discharge valve Soupape de refoulement Druckventil		
	Ø"	Ø mm	Ø"	Ø mm	A mm	B mm	C mm	D mm	E mm	F mm	G mm	H mm	L mm	M mm	N mm
	Z 30 126 Y	2 1/8	54.0	1 3/8	35.0	768	512	522	381	305	154	437	136	125	310
Z 40 126 Y	2 5/8	67.0	1 5/8	42.0	822	512	522	381	305	178	437	144	125	310	47.5

1	tappo di alta pressione	high pressure plug	bouchon haute pression	Stopfen Druckseite
2	tappo di bassa pressione	low pressure plug	bouchon basse pression	Stopfen Saugseite
3	tappo di carico olio	oil charge plug	bouchon charge d'huile	Stopfen Ölfüllung
4	spia livello olio	oil level sight glass	voyant de niveau huile	Ölschauglas
5	sede resistenza carter	crankcase heater seat	doigt de gant pour résistance de carter	Pos. für Ölumpfheizung
6	tappo scarico olio	oil drain plug	bouchon vidange d'huile	Stopfen Ölabblass
7	attacco per valvola iniezione liquido	liquid injection valve plug	bouchon electrov.injection de liquide	Stopfen Flüssigkeitseinspritzung
8	attacco per sensore iniezione liquido	liquid injection sensor plug	bouchon sensor injection de liquide	Stopfen Sensor
9	attacco pressostato diff. olio (b.p.)	oil pressure switch connection (l.p.)	raccord pressostat diff. huile (b.p.)	Öldruckschalter Niederdruckanschluss
10	attacco pressostato diff. olio (a.p.)	oil pressure switch connection (h.p.)	raccord pressostat diff. huile (h.p.)	Öldruckschalter Hochdruckanschluss
11	filtro olio	oil filter	filtre à huile	Ölfilter
12	tappo ritorno olio	oil return plug	bouchon retour d'huile	Stopfen Ölrückführung
13	tappo magnetico	magnetic plug	bouchon magnétique	Magnetstopfen
14	sensore massima temp. scarico	max. discharge temperature sensor	sensor max. temp. de refoulement	Druckgasfühler
15	attacco pressostato olio elettronico	electronic oil pressure switch connection	raccord pressostat diff. huile électronique	Elektronische Öldruckschalteranschluss
DV	rubinetto di compressione	discharge valve	soupape de refoulement	Druckventil
NP	targhetta	name plate	plaque signalétique	Verdichtertypschild
SD	staffetta di fissaggio del pressostato	oil pressure switch mounting bracket	support pour pressostat diff. huile	Öldruckschalterbügel
SV	rubinetto di aspirazione	suction valve	soupape d'aspiration	Saugventil

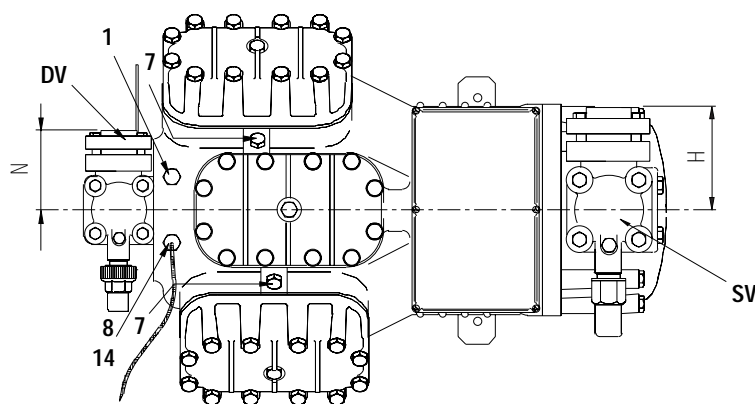
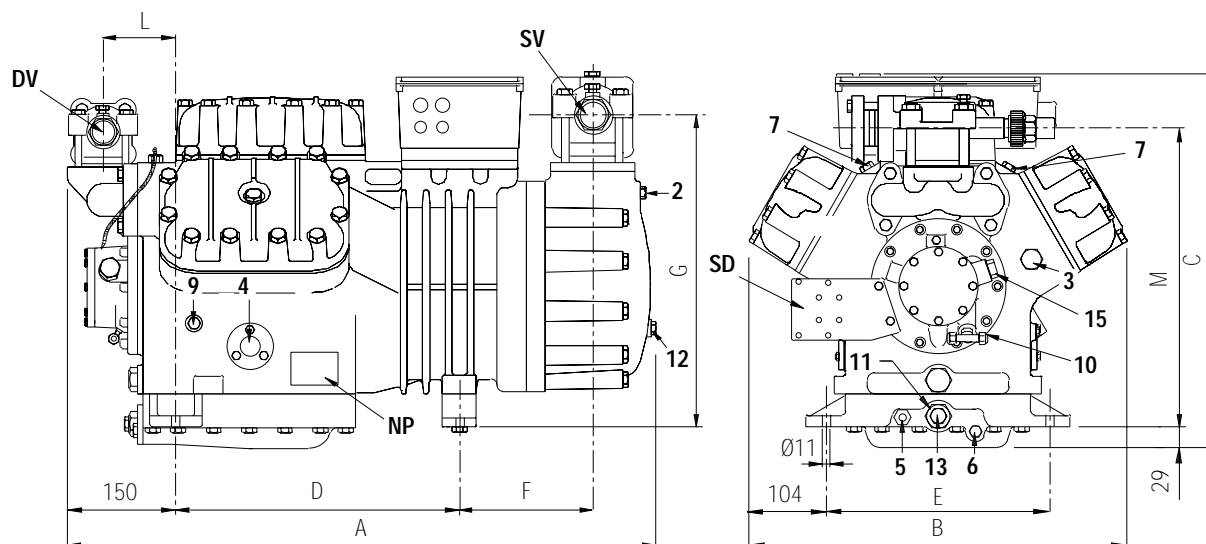

Supporto antivibrante

Vibration absorber

Support anti-vibrations

Vibrationsabsorber

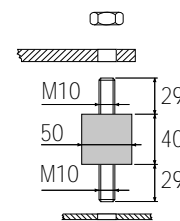

Serie	Series	Z
Série	Reihe	

	Rubinetto aspirazione Suction valve Soupape d'aspiration Saugventil		Rubinetto compressione Discharge valve Soupape de refoulement Druckventil		Lunghezza Length Longueur Länge	Larghezza Width Largeur Breite	Altezza Height Hauteur Höhe	Interassi di fissaggio Base mounting Trous de fixation Befestigungslöcher		Rubinetto aspirazione Suction valve Soupape d'aspiration Saugventil			Rubinetto compressione Discharge valve Soupape de refoulement Druckventil		
	Ø"	Ø mm	Ø"	Ø mm	A mm	B mm	C mm	D mm	E mm	F mm	G mm	H mm	L mm	M mm	N mm
Z 40 154 Y	2 5/8	67.0	1 5/8	42.0	790	512	522	381	305	178	437	144	103	412	110
Z 50 154 Y	2 5/8	67.0	1 5/8	42.0	790	512	522	381	305	178	437	144	103	412	110

1	tappo di alta pressione	high pressure plug	bouchon haute pression	Stopfen Druckseite
2	tappo di bassa pressione	low pressure plug	bouchon basse pression	Stopfen Saugseite
3	tappo di carico olio	oil charge plug	bouchon charge d'huile	Stopfen Ölfüllung
4	spia livello olio	oil level sight glass	voyant de niveau huile	Ölschauglas
5	sede resistenza carter	crankcase heater seat	doigt de gant pour résistance de carter	Pos. für Ölpumpeheizung
6	tappo scarico olio	oil drain plug	bouchon vidange d'huile	Stopfen Ölablass
7	attacco per valvola iniezione liquido	liquid injection valve plug	bouchon électrov.injection de liquide	Stopfen Flüssigkeitseinspritzung
8	attacco per sensore iniezione liquido	liquid injection sensor plug	bouchon sensor injection de liquide	Stopfen Sensor
9	attacco pressostato diff. olio (b.p.)	oil pressure switch connection (l.p.)	raccord pressostat diff. huile (b.p.)	Öldruckschalter Niederdruckanschluss
10	attacco pressostato diff. olio (a.p.)	oil pressure switch connection (h.p.)	raccord pressostat diff. huile (h.p.)	Öldruckschalter Hochdruckanschluss
11	filtro olio	oil filter	filtre à huile	Ölfilter
12	tappo ritorno olio	oil return plug	bouchon retour d'huile	Stopfen Ölrückführung
13	tappo magnetico	magnetic plug	bouchon magnétique	Magnetstopfen
14	sensore massima temp. scarico	max. discharge temperature sensor	sensor max. temp. de refoulement	Druckgasfühler
15	attacco pressostato olio elettronico	electronic oil pressure switch connection	raccord pressostat diff. huile électronique	Elektronische Öldruckschalteranschluss
DV	rubinetto di compressione	discharge valve	soupape de refoulement	Druckventil
NP	targhetta	name plate	plaque signalétique	Verdichtertypschild
SD	staffetta di fissaggio del pressostato	oil pressure switch mounting bracket	support pour pressostat diff. huile	Öldruckschalterbügel
SV	rubinetto di aspirazione	suction valve	soupape d'aspiration	Saugventil

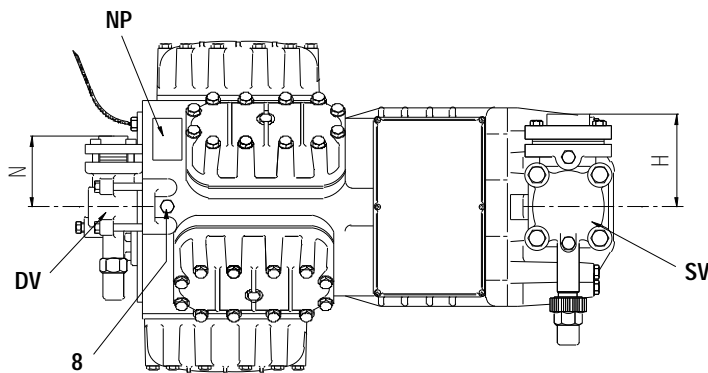
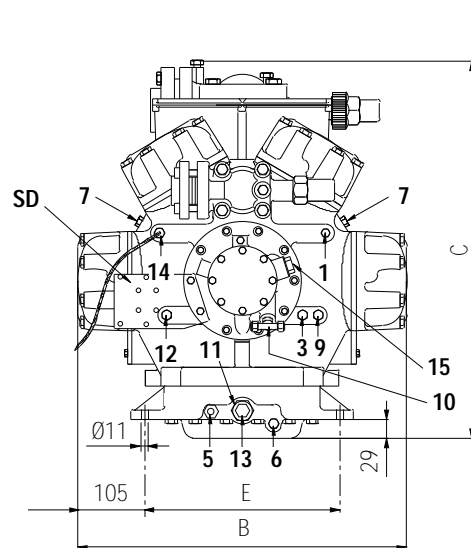
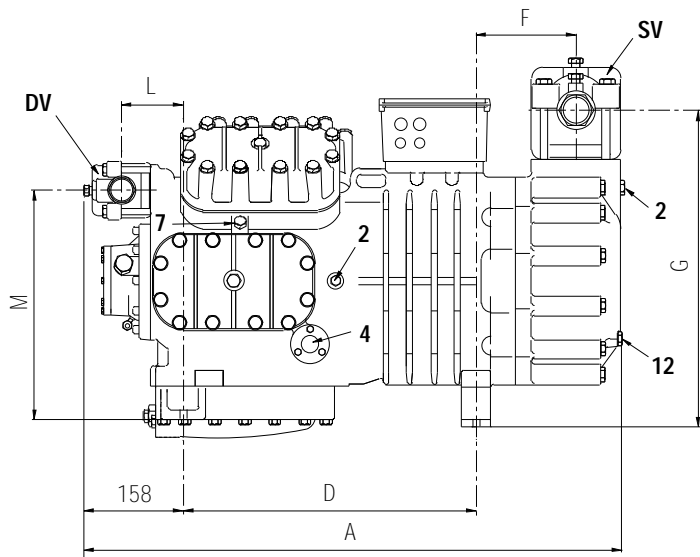

Supporto antivibrante

Vibration absorber

Support anti-vibrations

Vibrationsabsorber

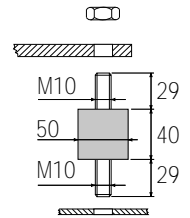

Serie	Series	W
Série	Reihe	

Compressore Compressor Compresseur Verdichter	Rubinetto aspirazione Suction valve Soupape d'aspiration Saugventil		Rubinetto compressione Discharge valve Soupape de refoulement Druckventil		Lunghezza Length Longueur Länge	Larghezza Width Largeur Breite	Altezza Height Hauteur Höhe	Interassi di fissaggio Base mounting Trous de fixation Befestigungslocher		Rubinetto aspirazione Suction valve Soupape d'aspiration Saugventil			Rubinetto compressione Discharge valve Soupape de refoulement Druckventil		
	Ø"	Ø mm	Ø"	Ø mm	A mm	B mm	C mm	D mm	E mm	F mm	G mm	H mm	L mm	M mm	N mm
W 40 142 Y	2 5/8	67.0	1 5/8	42.0	841	515	588	458	305	156	492	144	97	357	110
W 40 168 Y	2 5/8	67.0	1 5/8	42.0	841	515	588	458	305	156	492	144	97	357	110
W 50 168 Y	3 1/8	79.4	1 5/8	42.0	841	515	602	458	305	156	492	152	97	357	110
W 50 187 Y	3 1/8	79.4	1 5/8	42.0	841	515	602	458	305	156	492	152	97	357	110
W 60 187 Y	3 1/8	79.4	1 5/8	42.0	841	515	602	458	305	156	492	152	97	357	110
W 60 206 Y	3 1/8	79.4	2 1/8	54.0	841	515	602	458	305	156	492	152	97	357	183
W 70 206 Y	3 1/8	79.4	2 1/8	54.0	873	515	602	458	305	188	492	152	97	357	183
W 70 228 Y	3 1/8	79.4	2 1/8	54.0	873	515	602	458	305	188	492	152	97	357	183
W 75 228 Y	3 1/8	79.4	2 1/8	54.0	873	515	602	458	305	188	492	152	97	357	183
W 75 240 Y	3 1/8	79.4	2 1/8	54.0	873	515	602	458	305	188	492	152	97	357	183
W 80 240 Y	3 1/8	79.4	2 1/8	54.0	873	515	602	458	305	188	492	152	97	357	183

1	tappo di alta pressione	high pressure plug	bouchon haute pression	Stopfen Druckseite
2	tappo di bassa pressione	low pressure plug	bouchon basse pression	Stopfen Saugseite
3	tappo di carico olio	oil charge plug	bouchon charge d'huile	Stopfen Ölfüllung
4	spia livello olio	oil level sight glass	voyant de niveau huile	Ölschauglas
5	sede resistenza carter	crankcase heater seat	doigt de gant pour résistance de carter	Pos. für Ölsumpfeheizung
6	tappo scarico olio	oil drain plug	bouchon vidange d'huile	Stopfen Ölablass
7	attacco per valvola iniezione liquido	liquid injection valve plug	bouchon electrov.injection de liquide	Stopfen Flüssigkeitseinspritzung
8	attacco per sensore iniezione liquido	liquid injection sensor plug	bouchon sensor injection de liquide	Stopfen Sensor
9	attacco pressostato diff. olio (b.p.)	oil pressure switch connection (l.p.)	raccord pressostat diff. huile (b.p.)	Öldruckschalter Niederdruckanschluss
10	attacco pressostato diff. olio (a.p.)	oil pressure switch connection (h.p.)	raccord pressostat diff. huile (h.p.)	Öldruckschalter Hochdruckanschluss
11	filtro olio	oil filter	filtre à huile	Ölfilter
12	tappo ritorno olio	oil return plug	bouchon retour d'huile	Stopfen Ölrückführung
13	tappo magnetico	magnetic plug	bouchon magnétique	Magnetstopfen
14	sensore massima temp. scarico	max. discharge temperature sensor	sensor max. temp. de refoulement	Druckgasfühler
15	attacco pressostato olio elettronico	electronic oil pressure switch connection	raccord pressostat diff. huile électronique	Elektronische Öldruckschalteranschluss
DV	rubinetto di compressione	discharge valve	soupape de refoulement	Druckventil
NP	targhetta	name plate	plaque signalétique	Verdichtertypschild
SD	staffetta di fissaggio del pressostato	oil pressure switch mounting bracket	support pour pressostat diff. huile	Öldruckschalterbügel
SV	rubinetto di aspirazione	suction valve	soupape d'aspiration	Saugventil

Accessori

Optional equipments

Accessories

Zubehöre

	serie compressore - compressor series - séries du compresseur - Verdichterreihe									
	A	B	C	D	F	Q	S	V	Z	W
Controllo della capacità frigorifera Capacity control Régulateur de puissance Leistungsregelung	•	•	•	•	•	○	○	○	○	○
Aviamento a vuoto Unload starting Démarrage à vide Anlaufentlastung	•	•	•	•	○	○	○	○	○	○
Riscaldatore olio carter Crankcase heater Résistance de carter Ölumpfheizung	○	○	○	○	○	○	○	○	○	○
Motoventilatore raffreddamento testate Head cooling fan motor Motoventilateur refroid. des têtes Kopflüfter für Zylinderköpfe	○	○	○	○	○	○	○	○	○	○
Iniezione di liquido Liquid injection Injection de liquide Flüssigkeitseinspritzung	•	•	•	•	•	•	○	○	○	○
Pressostato olio elettronico Electronic oil pressure switch Pressostat diff. huile électronique Elektronische Öldruckschalter	•	•	•	•	•	•	•	○	○	○
Sensore max. temperatura compressione Maximum discharge temperature sensor Sensor max. temperature de refoulement Druckgasfühler	•	•	•	•	•	○	○	◇	◇	◇

FCAT01-07

- non disponibile - not available - pas disponible - nicht verfügbar
- a richiesta - on request - sur demand - auf Anfrage
- ◇ dotazione standard - standard equipment - équipement standard - Standard Ausrüstung



FRASCOLD spa

Head Office

Via Barbara Melzi 105
I-20027 Rescaldina (MI)
ITALY
phone +39-0331-7422.01
fax +39-0331-576102
<http://www.frascold.it>
e-mail: frascold@frascold.it

Branch Office

FRASCOLD Asia

10 Jalan Hikayat
Singapore 769855
SINGAPORE
phone +65-6851-7318
fax +65-6851-7055
mobile +65-967-71827
e-mail: frascold@singnet.com.sg
